

LM80

Laser level sensor

Intermediate range continuous laser level and position sensor



Level measurement made easy

- Maintenance free, non-contact continuous level sensor
- No calibration required
- Continuous level monitoring for granular solid materials and opaque liquids
- Measures solids and opaque liquids at any angle
- Built-in laser pointer for accurate alignment in narrow or tall vessels
- Auto-ranging to measure all levels
- Available non condensing heated optics prevent condensation issues

A convenient solution

- Rugged and robust powder coated aluminum or stainless steel enclosures can be used in any environment
- CSA, ATEX and IECEx potentially explosive atmosphere ratings
- Easy to install and configure without filling or emptying the vessel
- 4-20 mA and dual relay outputs

High performance

- Less than 0.3° beam divergence for precision targeting
- No false echoes
- Up to 500 ft. / 150 m measuring range
- Three updates per second
- Can penetrate moderate dust

Many different materials

- Measures all clearly visible surfaces irrespective of texture, granularity, slope and / or color
- Measures any opaque liquid level independent of dielectric constant or other physical properties
- Accurately measures to the surface of mineral ores, grains, and synthetic materials
- Examples include: gold and metal ores, coal, corn, rice, coffee, plastic pellets, oils and fuels

Many different vessels

- Works in all types of storage vessels including silos, tanks, feed chutes, bunkers and hoppers
- Can measure through narrow gaps
- Reads to the bottom of silos and tanks

Options and accessories

- Stainless steel dust tubes and cooling tubes
- Stainless steel 4 and 6 inch universal mounting plates sized for ANSI 150 and DIN PN10 flanges
- Stainless steel raised face ANSI and DIN Flanges
- 4" Triclover fittings
- Handheld configuration device (LCD2)

LM80

Laser level sensor

Overview

The laser level sensor (LM80) is a non-contact, level measuring instrument designed for granular solid materials and opaque liquids. Based on pulsed laser technology, the LM80 embodies speed and accuracy in a single, easy to use and install product. The characteristic narrow beam divergence of the laser permits direct aiming to the target surface without interference from structure or falling material. With both continuous 4-20 mA and single point relay outputs, the LM80 can operate as a process control sensor while simultaneously providing high and low alarms. Whether measuring a few meters into the confined space of a crusher, or to the bottom of the tallest silo, the LM80 with its laser pointer and long range is the plug-and-play solution to level measurement.

Level measurement with laser technology

The LM80 uses a high speed laser pulse to measure distance. The laser light is emitted towards the surface and some of it reflects back to the instrument where it is detected by a sensitive optical receiver. The time it takes for the light to travel to the surface and back to the instrument is directly proportional to the distance between the instrument and the surface. Using a time-of-flight calculation, and knowing the height of the vessel, the LM80 accurately measures the distance to the target surface using the equation below:

$$\text{Level} = \text{height} - \frac{\text{speed of light} \times \text{time-of-flight}}{2}$$

The unique characteristics of laser light give the LM80 significant performance advantages over other technologies. The narrow, long range beam can measure both near and far distances while the optical wavelength makes it easy to evaluate applications. If you can see the surface clearly, the LM80 can measure the level.

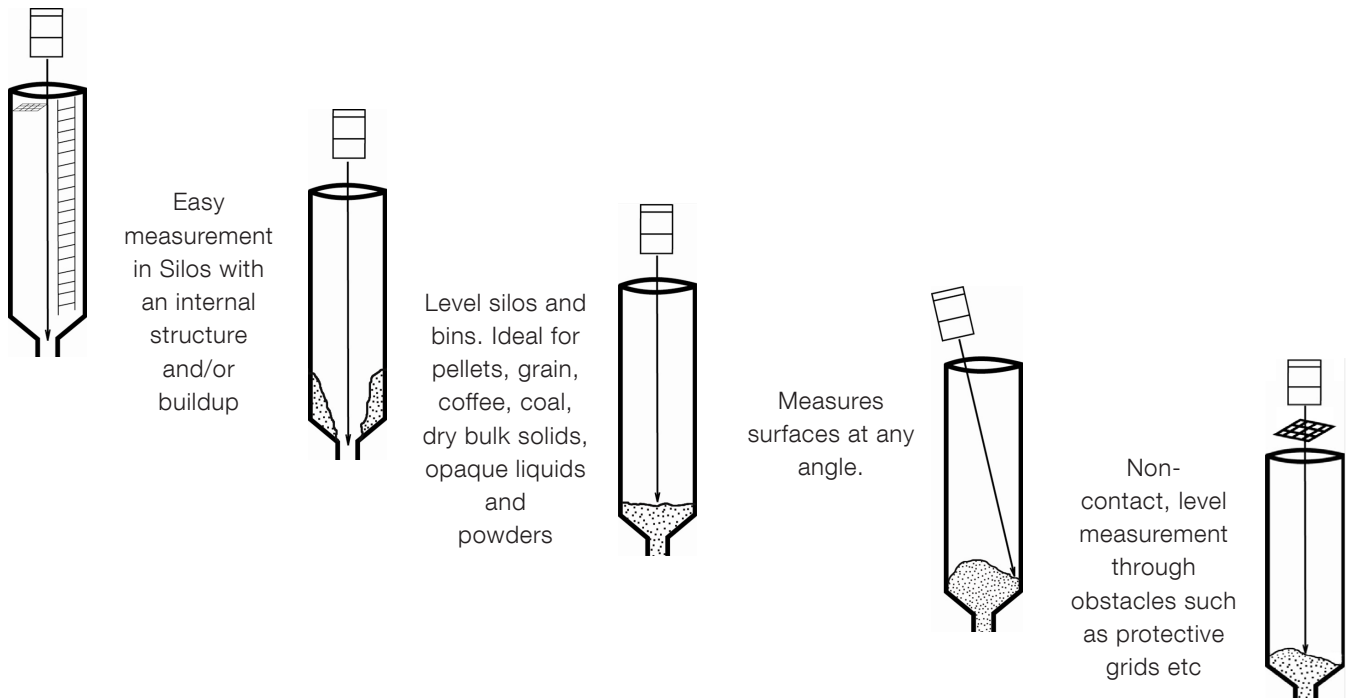

Range guide

The LM80 is mounted on top of a storage vessel aiming downwards towards the surface. Using the visible laser pointer, the position and angle of the LM80 can be adjusted so that the instrument measures all the way to the bottom of the vessel. Settings such as: the distances for the 4-20 mA output; and the relay switching points, can be entered into the instrument either before installation, or in situ using the laser configuration (LCD2) accessory. Another recommended accessory is the stainless steel dust tube (P801) which keeps the optical system of the LM80 clean for long periods.

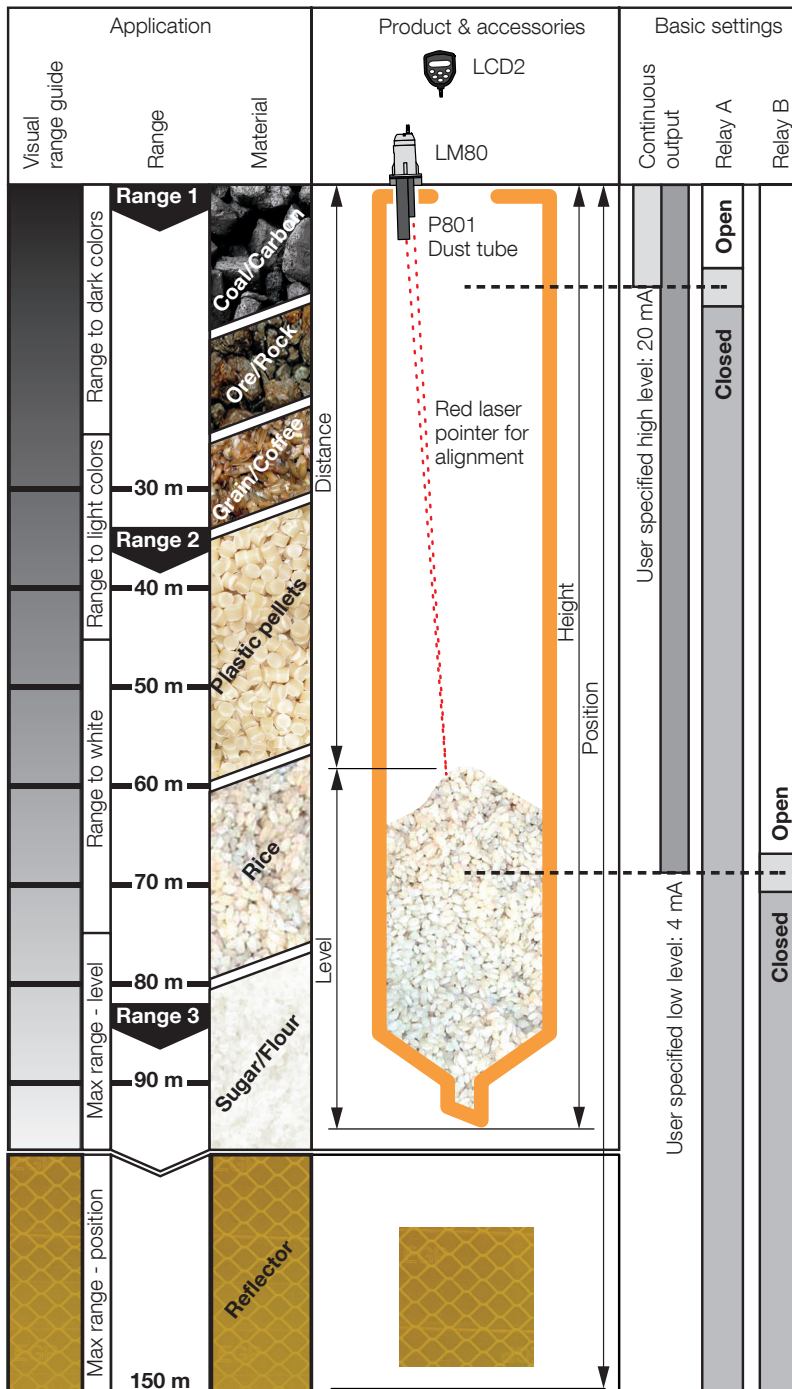

Another recommended accessory is the stainless steel dust tube (P801) which keeps the optical system of the LM80 clean for long periods.

Range explained

The LM80 is able to measure the level in tall silos because of the inherent long distance capability of laser technology. The laser has a natural advantage because it gets strong, clear signals from most types of granular solid materials. As the laser beam doesn't spread out and lose strength as it travels, there is little signal loss with increased distance.

Auto-ranging

Auto-ranging is a hardware feature which increases the range of the internal timing circuitry of the LM80. It does this in response to the 4-20mA or relay set points that are entered by the user. If these settings are less than 35 m (114.8 ft) then automatic "Range 1" is used. Between 35 m (114.8 ft) and 85 m (278.9 ft), automatic "Range 2" is selected. As the LM80 switches between these ranges there is no loss of accuracy, only a slight reduction in measuring speed.

Ultimate range

The ultimate limit of range for the LM80 depends on the reflectivity of the material being measured, not on the height of the vessel. Dark colored materials can be measured over a shorter range than light colored materials. Using the chart on the left, a visual comparison between the graded "Visual range guide" strip and the surface to be measured tells you what range is practically possible.

Positioning range

When the LM80 is used for positioning applications with a reflective target it can measure to a maximum distance of 150 m (500 ft).

LM80

Laser level sensor



Specifications

Measurements	
Range	0.5 m (1.5 ft) to >25 m (82 ft) - dark colored surfaces 0.5 m (1.5 ft) to >45 m (150 ft) - light colored surfaces 0.5 m (1.5 ft) to 150 m (500 ft) - reflective targets in positioning applications
Resolution	±10 mm (0.4 in) ±7 mm (0.3 in) with 12 second sliding window
Accuracy	±30 mm (1.2 in) ±25 mm (1.0 in) with 12 second sliding window
Update rate	3 readings per second (maximum), 1 reading per minute (minimum)
Operating temperature	-40°C to +60°C / -40°F to +140°F Note: While the initial (cold start) accuracy of the LM80 will be within specifications, a settling period of approximately 15 minutes is recommended to allow the electronics to warm up and the internal temperature to stabilize.
Survival temperature	-40°C to +80°C / -40°F to +176°F
Pressure	Atmospheric
Outputs	
Analog	4-20 mA, NAMUR compliant non-isolated and self powered
Digital (Relay)	2 SPST relays: 0.5 A at 120 VAC, 0.25 A at 250 VAC, 1 A at 24 VDC, 0.5 A at 60 VDC
Communication	Standard male DB9 connector - RS232 for testing, troubleshooting and configuration 19200 baud, 8 data bits, 1 stop bit, no parity, no flow control
Power supply	
Voltage	24 V DC typical (18 to 32 V DC)
Current	0.4 A peak (start up 17W for less than 100 ms), 0.2 A continuous 0.6 A peak, 0.4 A continuous with non-condensing optics
Mechanical	
Base plate diameter	Flange - 140 mm (5.51 in) Triclover - 120 mm (4.72 in)
Length	Flange - 172 mm (6.77 in) Triclover - 166 mm (6.54 in)
Weight	Aluminum enclosure - 1.6 kg (3.53 lbs) Aluminum enclosure with triclover - 2.2 kg (4.85 lbs) 316 Stainless steel enclosure - 4.2 kg (9.26 lbs)
Enclosure material	Powder coated aluminum standard, 316 stainless steel option
O-ring seal material	Buna-N (Nitrile Rubber)
Mounting / process connection	Flange - 4 holes, 8.5 mm (0.33 in) diameter on 120 mm (4.72 in) diameter circle Triclover - 316 Stainless steel plate with seal groove

Optical

Total optical aperture	90 mm (3 in)
Measuring laser lens diameter	25 mm (1 in)
Receiver lens diameter	50 mm (1.97 in)
Lens material	Acrylic
Lens impact resistance	Impact tested at 4 joule
Beam divergence	$\Delta < 0.3^\circ$
Beam spot diameter	$2R \tan\left(\frac{\Delta}{2}\right)$
	Where R is the range to the target and Δ is the beam divergence
Beam direction	$90^\circ \pm 1^\circ$ from mounting flange

Laser

Measuring laser	905 nm near infrared pulsed semiconductor laser 12 mW average power output 20 W peak power output
Pointing laser	635 nm red semiconductor laser 3 mW continuous
Measuring laser life expectancy	25 years typical MTBF
Measuring laser safety	 Always on IEC60825-1 class 1M laser A class 1M laser is safe for all conditions of use except when passed through magnifying optics. This means the maximum permissible exposure cannot be exceeded when viewing the laser with the naked eye without the aid of magnifying optics.
Pointing laser safety	 Intermittent IEC80825-1 class 3R laser Laser comes on at power up for 2 minutes, it can be turned back on for commissioning using the LCD2 communications and configuration device. A class 3R laser is considered safe if handled carefully, with restricted beam viewing. With a class 3R laser the maximum permissible exposure can be exceeded when viewing the laser with the naked eye, but with a low risk of injury.

Purge

Purge air flow	Must be oil free dry air recommended flow between 0.5 and 4 l/minute maximum pressure 5.5 bar (80 psi)
Purge fitting	1/8 NPT

Environmental

Enclosure rating	IP66/Nema 4X (Dust proof, can be washed down with high pressure hose)
Gas rating	This equipment can be used in flammable gases or vapor hazardous locations. Ambient temperature -40 to +60 °C (-40 to +140 °F)





Documentation for LM80 laser level sensor is available for download from www.abb.com/level

LM80

Laser level sensor

Approvals

The instrument is certified with the following environmental safety ratings which must not be exceeded. Copies of instrument certifications are available on request.

<p>CE</p> 	<p>Quality standard : ISO9001:2008 ATEX directive 94/9/EC Electromagnetic compatibility directive 2004/108/EC Low voltage directive 2006/95/EC CE marking directive 93/68/EEC</p>	<p>Harmonized standards applied: EN 60079-0:2012, EN 60079-15:2010 EN 60079-28:2007, EN 60079-31:2009 EN/IEC 61326-1 electrical equipment for measurement, control and laboratory use - EMC requirements EN/IEC 60825-1 safety of laser products - part 1: equipment classification, requirements and user's guide</p>
<p>ATEX, IECEx</p> 	<p>Notified body: SIRA Certification service, Rake Lane, Eccleston, Chester, CH4 9JN, England II 3G Ex nA nC IIC T4 Gc (-40 °C ≤ Ta ≤ +60 °C) II 3G Ex op is IIC T4 Gc (-40 °C ≤ Ta ≤ +60 °C) II 2D Ex tb IIIC T85°C Db (-40 °C ≤ Ta ≤ +60 °C)</p>	<p>Sira 07ATEX4179X Sira 07ATEX9180X IECEX SIR 12.0120X</p>
<p>CSA</p> 	<p>Class I, Division 2, Groups A, B, C and D; Class II and III, Groups E, F and G;T4A; (-20 °C < Tamb < +65 °C) US Ex nA nC IIC T4; Ex tb T85°C (-20 °C < Tamb < +60°C) Class I, Zone 2, AEx nA nC IIC T4</p>	
<p>FM</p> 	<p>NI Class I, Division 2, Groups A, B, C and D; DIP Class II and III, Division 1, Groups E, F and G; T4A</p>	
<p>(pending) GOST-R</p> 	<p>2ExnAnC[]CT4</p>	

Electrical connections

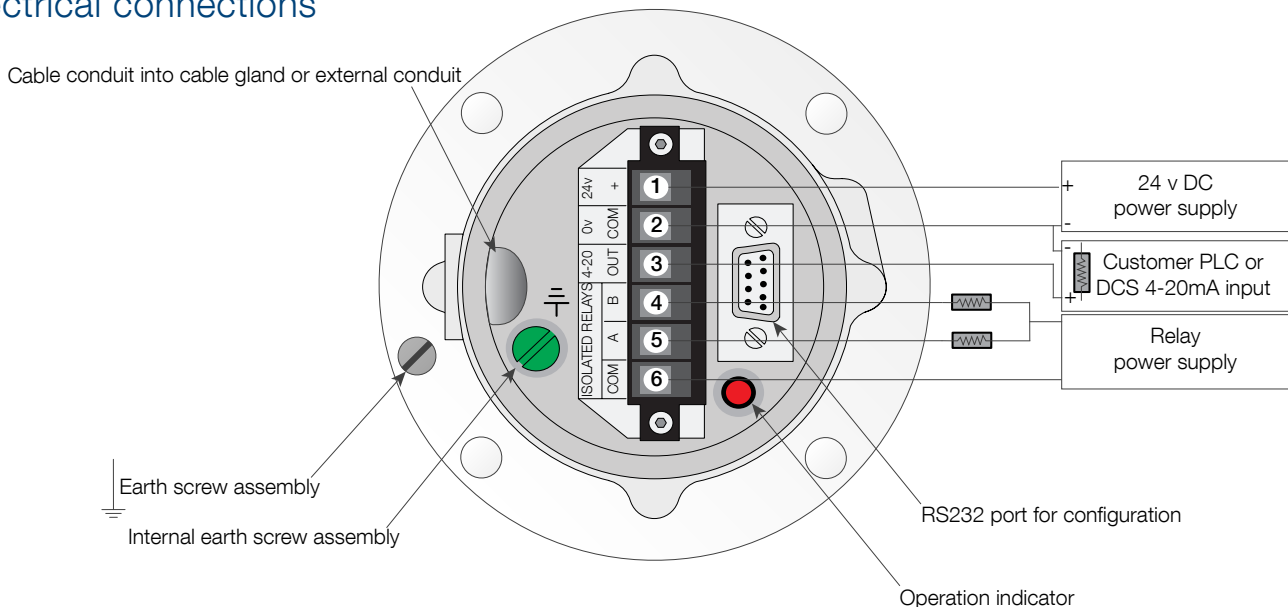

Dimensions

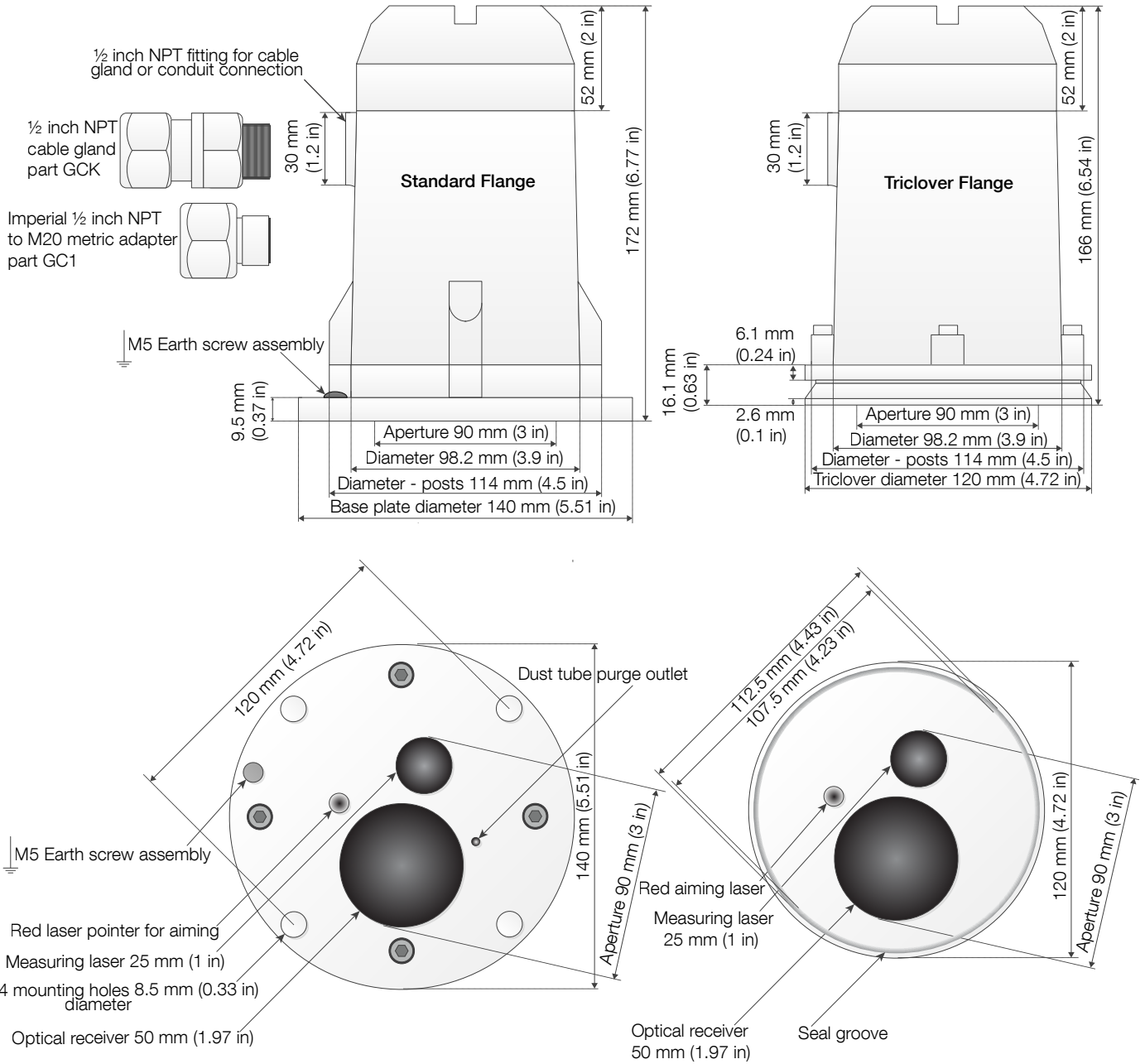

LM80 Laser level sensor

Accessories



Dust tube (P801)

Base plate diameter	140 mm (5.51 in) mounts on LM80 standard flange
Length	257.2 mm (10.125 in)
Material	304 Stainless steel
Gasket material	Black neoprene rubber durometer ratingd shore 60A
Function	Static air space prevents dust buildup, can be purged

Cooling tube (P802)

Base plate diameter	140 mm (5.51 in) mounts on LM80 standard flange
Mounting plate diameter	140 mm (5.51 in) compatible with LM80 mounting accessories
Length	260.4 mm (10.25 in)
Material	304 Stainless steel
Function	Offset from hot process interface to allow convection cooling, can be purged

Mounting plates

Nominal diameter	4 in / DN 100	6 in / DN 150
Part number	P804	P806
Outer diameter	228 mm (8.96 in)	284 mm (11.18 in)
Mounting bolt pattern	Dual pattern ANSI/DIN ANSI class 150 : 8 bolts, size 5/8 in, bolt circle 7.5 in DIN PN 10 : 8 bolts, size 18 mm, bolt circle 180 mm	Dual pattern ANSI/DIN ANSI class 150 : 8 bolts, size 3/4 in, bolt circle 9.5 in DIN PN 10 : 8 bolts, size 22 mm, bolt circle 240 mm
Material	304 Stainless steel	
Pressure rating	No pressure rating, atmospheric pressure only	

Mounting flanges

Nominal diameter	4 in raised face	6 in raised face	DN 100	DN 150
Part number	F804	F806	F810	F815
Outer diameter	9 in	11 in	220 mm	285 mm
Mounting bolt pattern	ANSI class 150 8 bolts, size 5/8 in Bolt circle 7.5 in	ANSI class 150 8 bolts, size 3/4 in Bolt circle 9.5 in	PN 10 8 bolts, size 18 mm Bolt circle 180 mm	PN 10 8 bolts, size 22 mm Bolt circle 240 mm
Material	304 Stainless steel			
Pressure rating	No pressure rating, atmospheric pressure only			

Adjustable swivel flange (S800)

Outer diameter	180 mm (7.1 in)
Mounting bolt pattern	4 bolt holes, 8.5 mm (0.33 in) diameter, bolt circle 160 mm (6.29 in)
Height	25.4 mm (1 in)
Tilt angle for aiming	Continuously adjustable from 0° to 6°
Material	Aluminum

Adjustable pivot bracket (A800)

Outer diameter / width	160 mm (6.3 in)
Opening diameter	90 mm (3.54 in)
Mounting plate thickness	4.76 mm (0.19 in)
Mounting bolt	HHCS screw 5/16-18, bolt hole 8.33 mm (0.33 in)
Height of pivot	25.4 mm (1 in)
Tilt angle for aiming	Continuously adjustable over 180°
Material	304 Stainless steel

LM80

Laser level sensor

High pressure sight glass (HPSG)	
Window diameter	101.6 mm (4 in)
Outer diameter	152.4 mm (6 in)
Spray ring	Open channel, 1/8 NPT fitting for purge or cleaning fluid injection
Thickness	12.7 mm (0.5 in)
Material	316 Stainless steel
Pressure rating	10 bar (150 psi)
Temperature rating	230 °C (450 °F)
Communication/configuration device and local display (LCD2)	
Protocol	RS232 ASCII menus
Connector	Standard female DB9
Interface	Monochrome LCD display / 6 button keypad
Size	Width 55 mm (2.17 in), Height 97 mm (3.82 in), thickness 32.5 mm (1.28 in)
Material	Plastic enclosure
Cable length	150 cm (59 in)
Warning	Not rated for dust or gas / cannot be used is hazardous area
RS232 to USB cable (USBR)	
Function	Connect to standard PC for configuration
Description	Made up of two cables that work together: Standard DB9 female to female null modem RS232 cable Standard male DB9 to full size type B female USB
Cable length	Null modem DB9 cable 305 cm (120 in) DB9 to USB cable 45 cm (17.7 in)
Recommended software	Windows: PuTTY free open source terminal emulator Mac OS X: Terminal built in terminal emulator
Warning	Not rated for dust or gas / cannot be used is hazardous area
Reflector (REFL)	
Function	Reflective panel for positioning applications up to 150 m
Size	90 cm x 90 cm (36 in x 36 in)
Material	Aluminum with reflective paint
Cable glands (GCK)	
Description	Set of 2 Ex cable glands with 1/2 in. NPT thread, size 0 / 8 mm and size 00 / 12 mm
Metric adaptor (GC1)	
Description	Exd/e Flameproof imperial to metric adaptor, 1/2 inch NPT to M20
Function	Enables use of metric M20 threaded conduits or cable glands with LM80
Battery pack (BPK)	
Function	Provide stand-alone power to LM80 for mobility and demonstration purposes
Battery	2 standard 9 volt batteries
Height	97.5 mm (3.84 in)
Diameter	110 mm (4.33 in)
Connector	Standard male DB9 compatible with LCD2 and USBR
Demo Kit	
Description	Rugged carrying case with LM80, dust tube, LCD2 and battery pack

Accessory dimensions

Dust tube (P801)

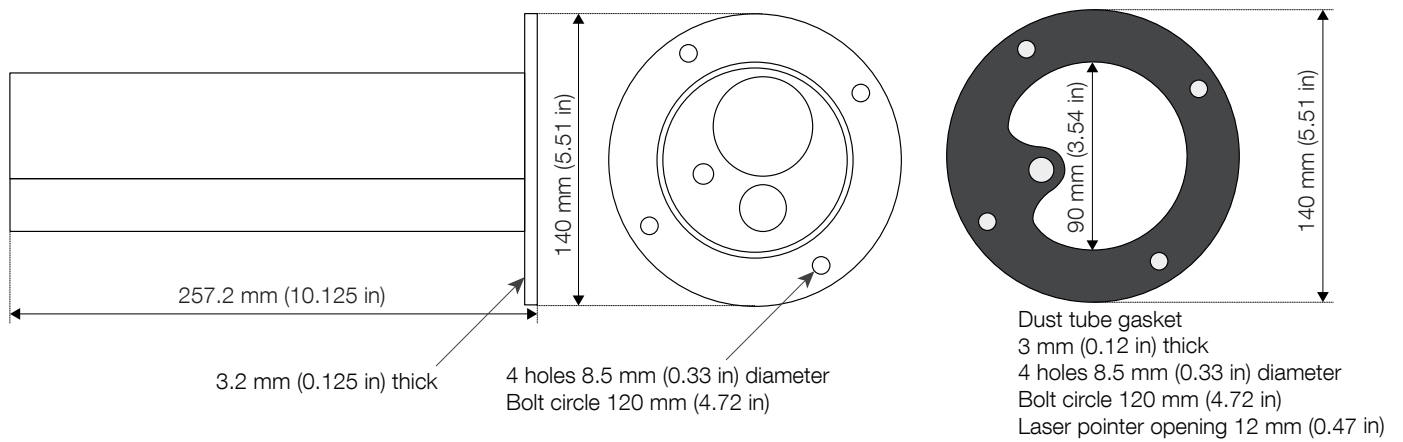

Cooling tube (P802)

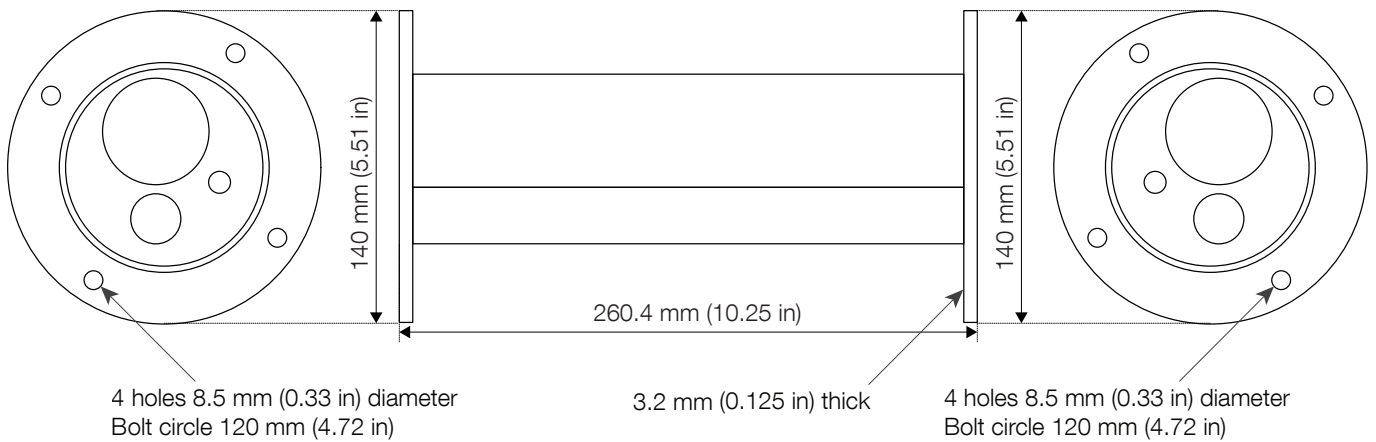

LM80

Laser level sensor

Mounting accessories

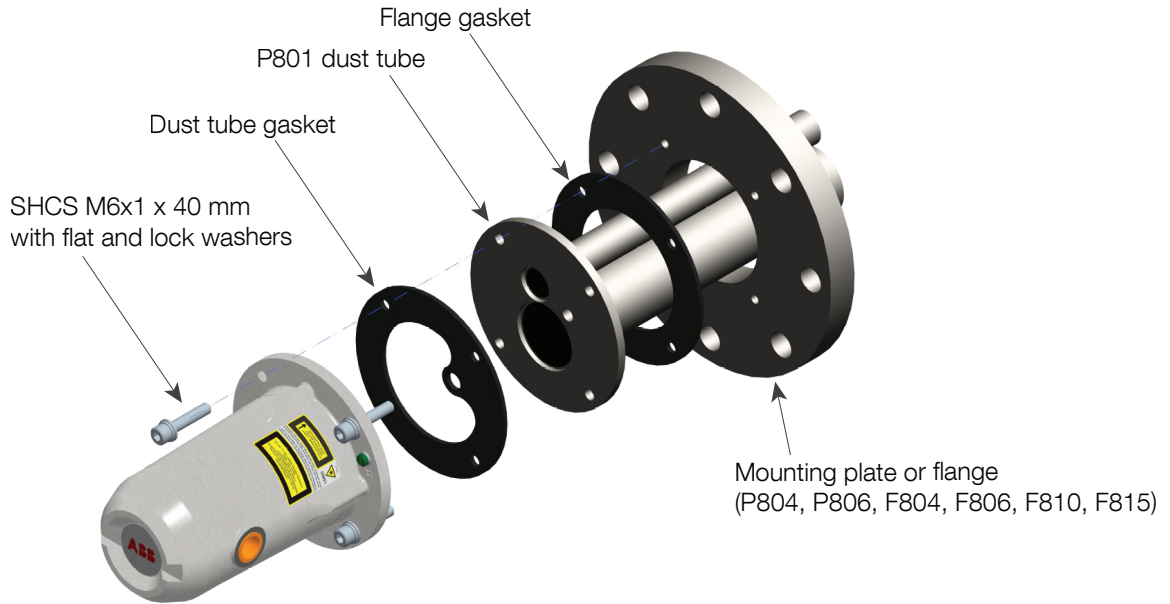

4 inch/DIN 100 mounting plate (P804)

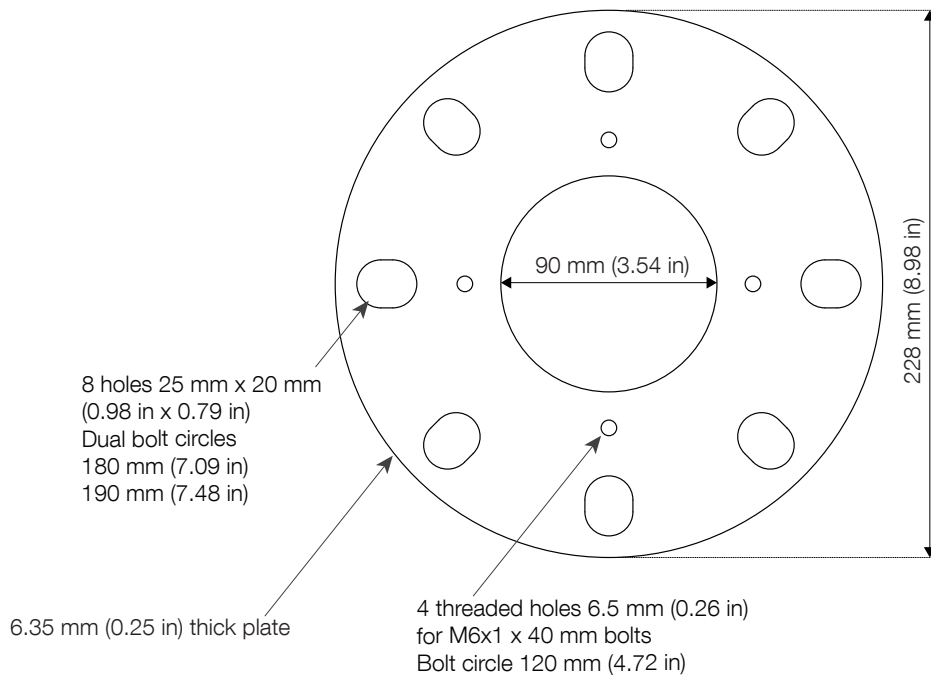

6 inch/DIN 150 mounting plate (P806)

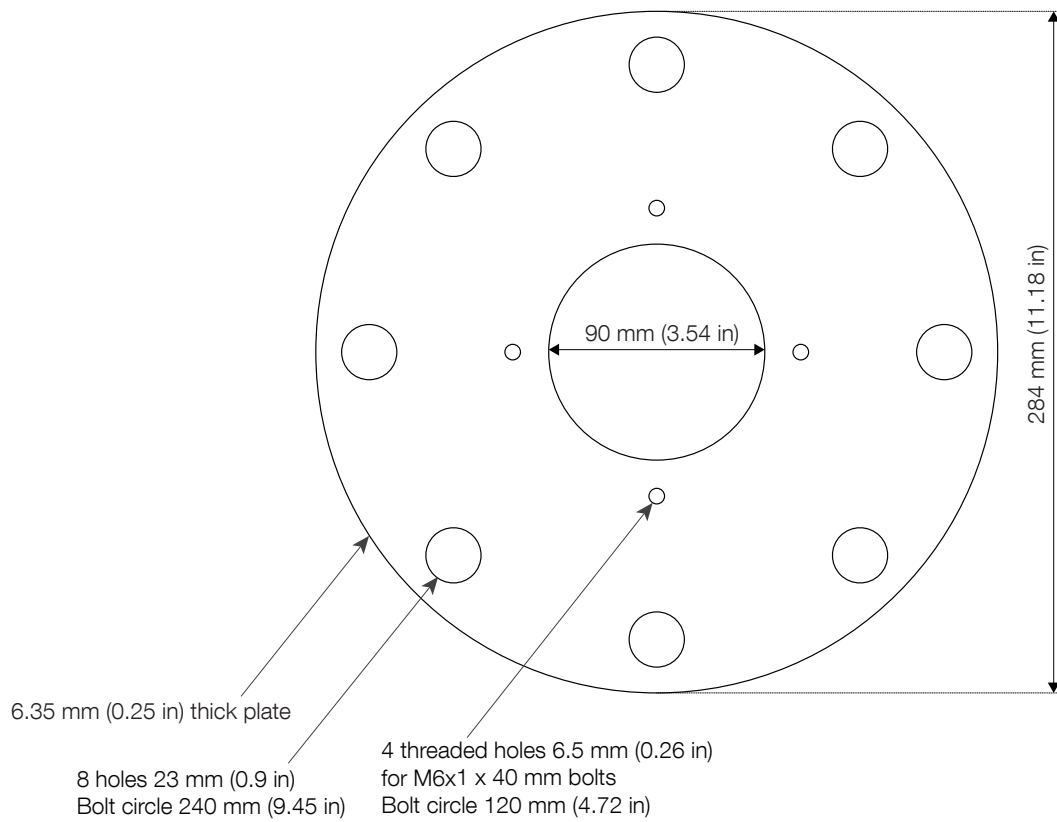

LM80

Laser level sensor

4 inch raised face mounting flange (F804)

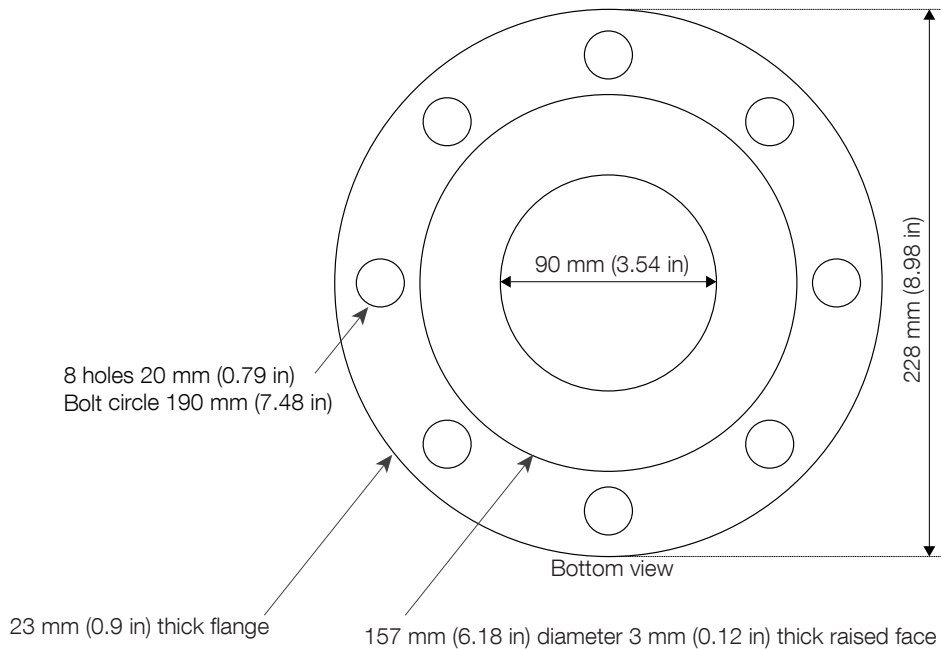
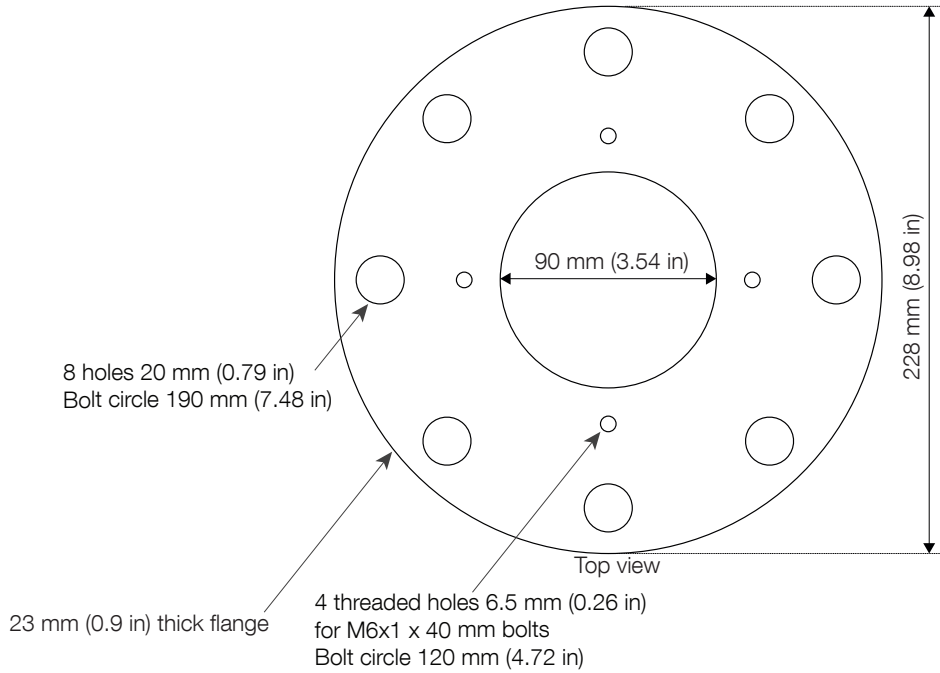

6 inch raised face mounting flange (F806)

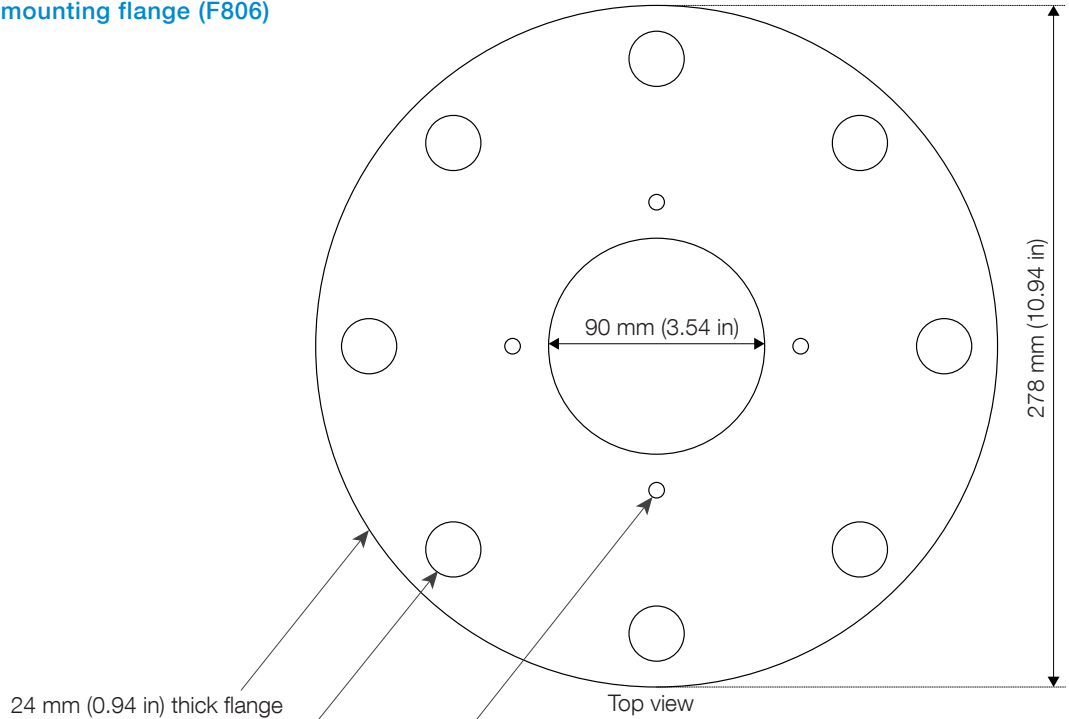

24 mm (0.94 in) thick flange

8 holes 22 mm (0.87 in)
Bolt circle 241 mm (9.49 in)

4 threaded holes 6.5 mm (0.26 in)
for M6x1 x 40 mm bolts
Bolt circle 120 mm (4.72 in)

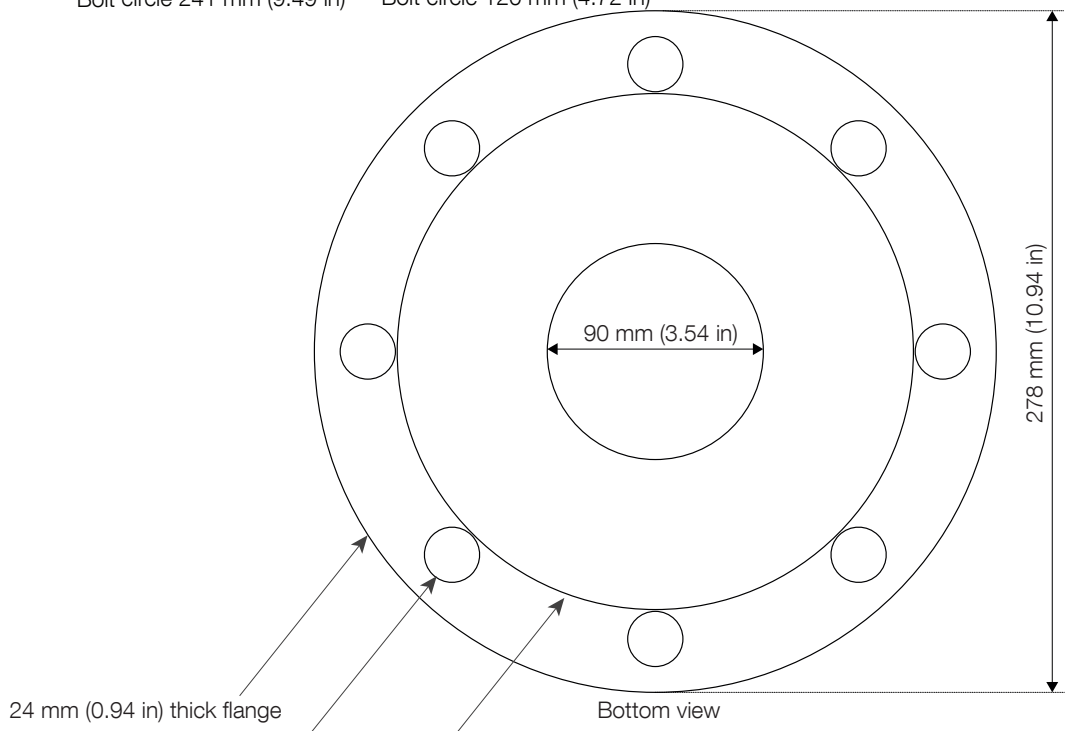

24 mm (0.94 in) thick flange

8 holes 22 mm (0.87 in)
Bolt circle 241 mm (9.49 in)

215 mm (8.46 in) diameter 3 mm (0.12 in) thick raised face

LM80

Laser level sensor

DIN 100 mounting flange (F810)

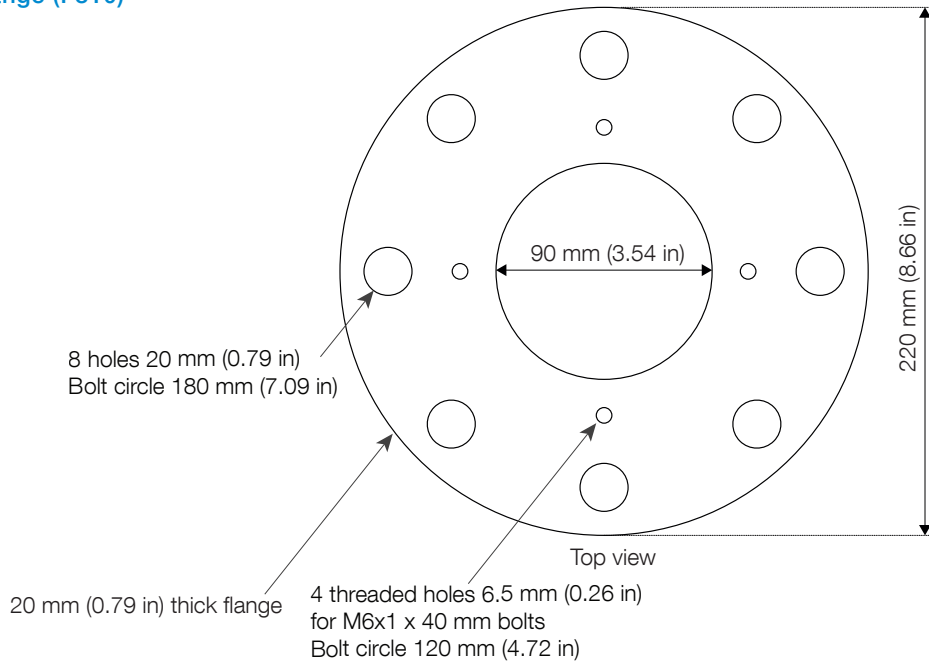

DIN 150 mounting flange (F815)

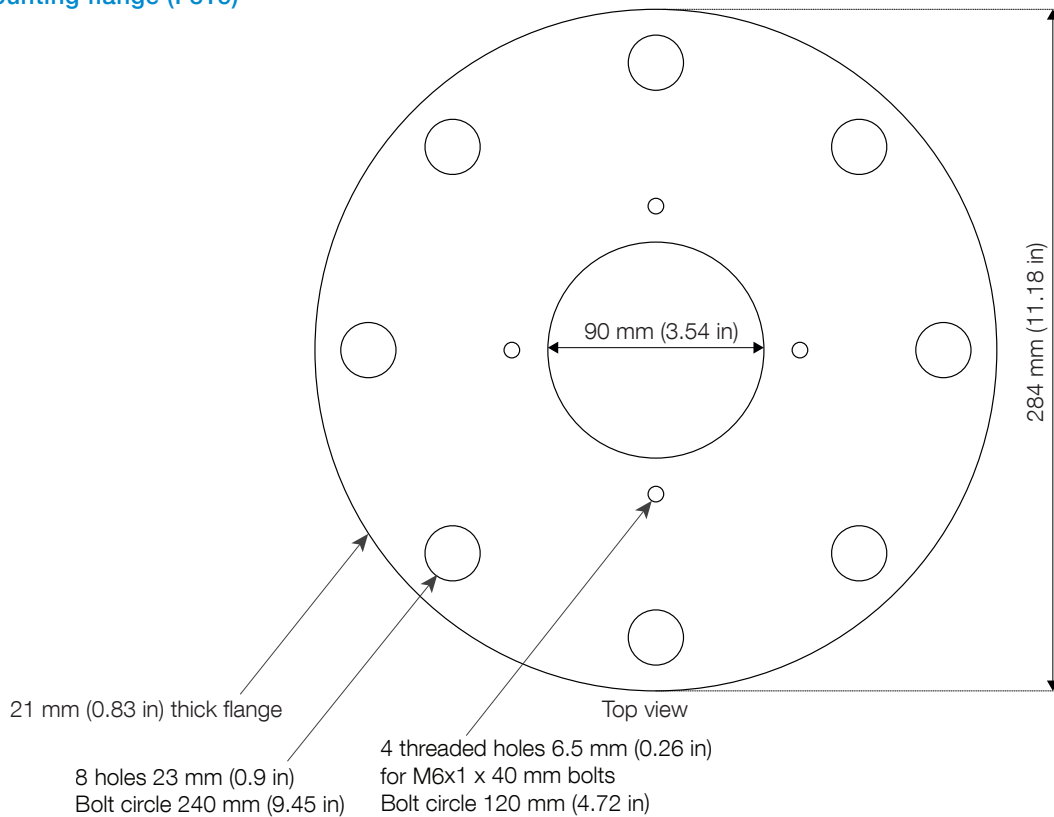

Swivel flange (S800)

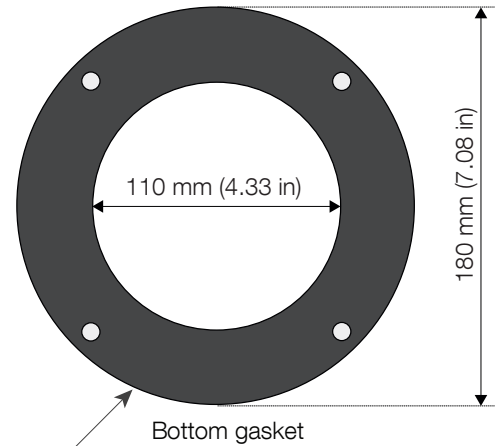
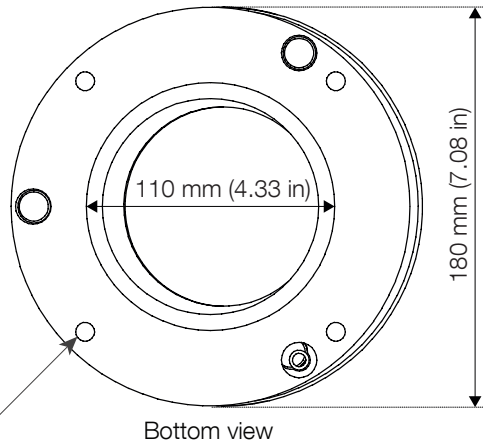
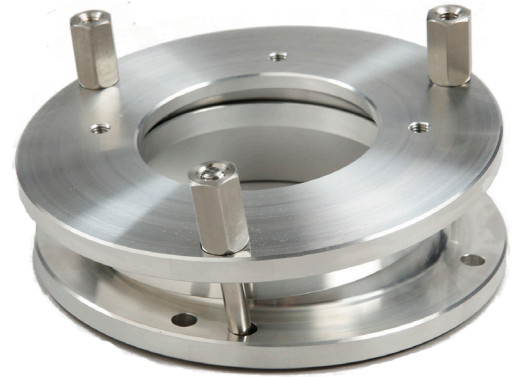
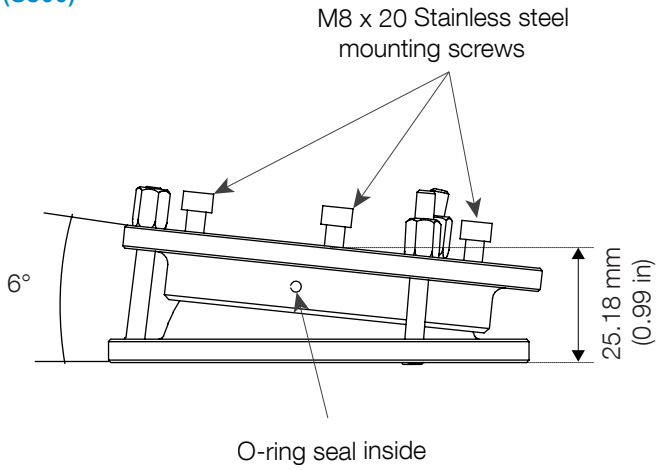

4 holes 8.5 mm (0.33 in) diameter
Bolt circle 160 mm (6.29 in)

3 mm (0.12 in) thick

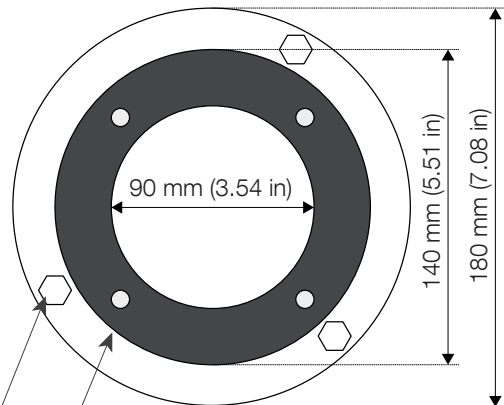

3 mm (0.12 in) thick gasket
4 holes 8.5 mm (0.33 in) diameter
Bolt circle 120 mm (4.72 in)

LM80

Laser level sensor

Adjustable pivot bracket (A800)

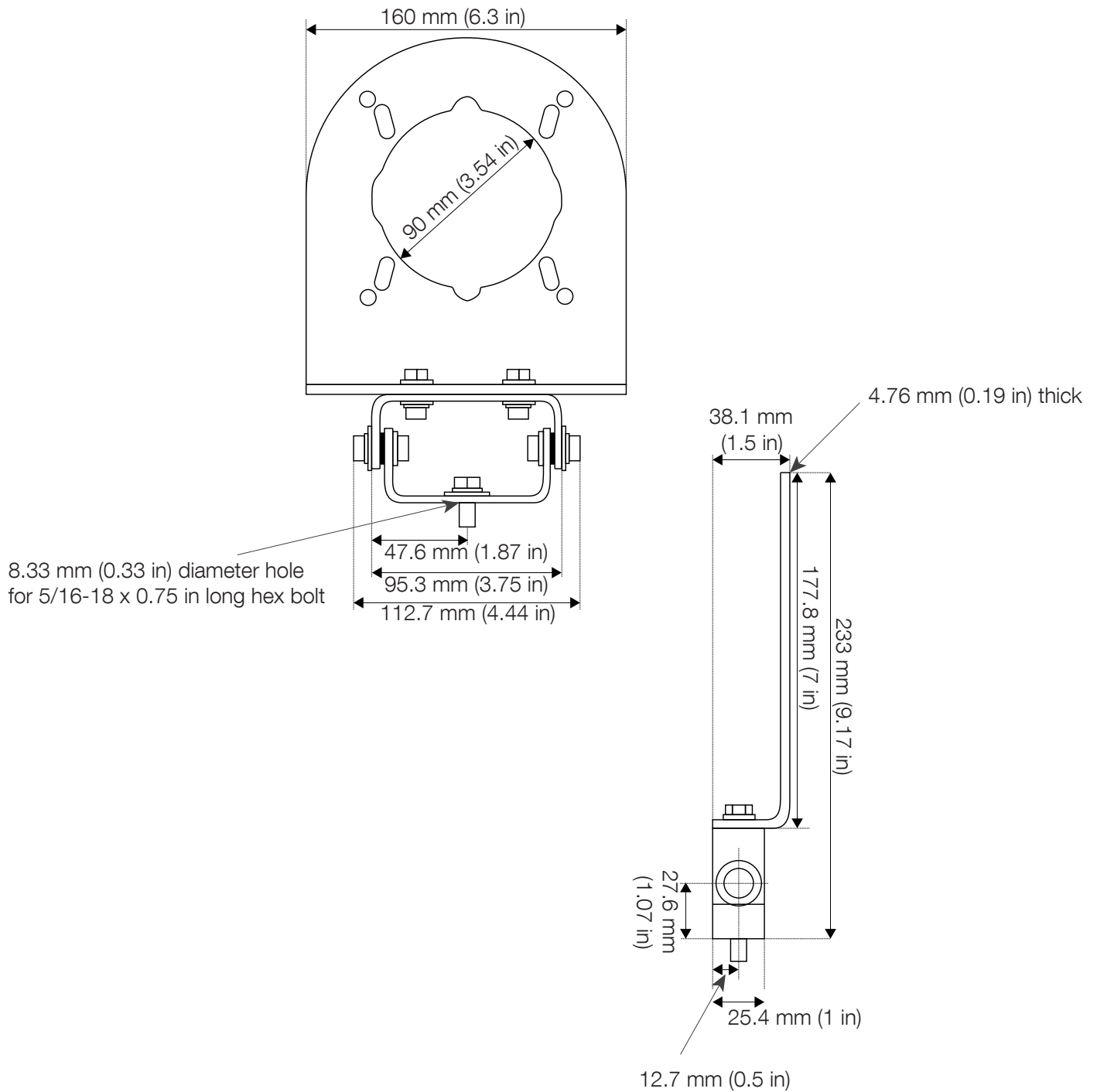

Miscellaneous Accessories

High pressure sight glass (HPSG)

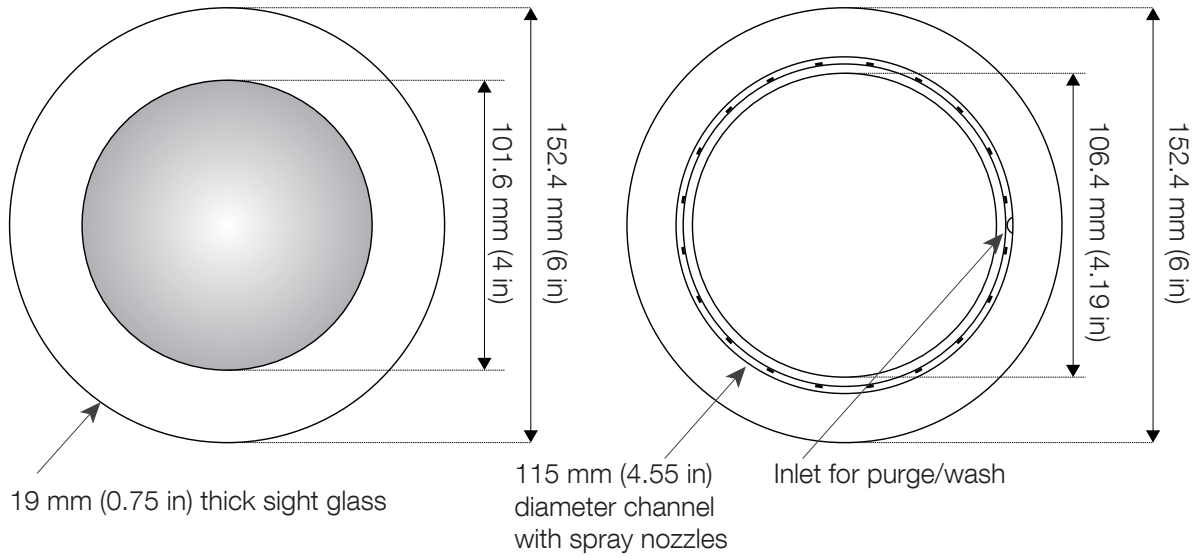

Communication/configuration device and local display (LCD2)

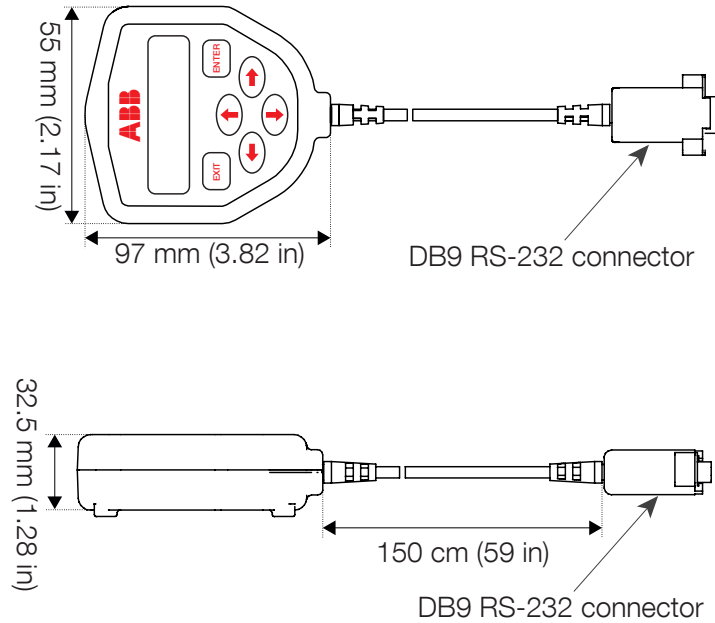

LM80

Laser level sensor

RS232 to USB cable (USBR)

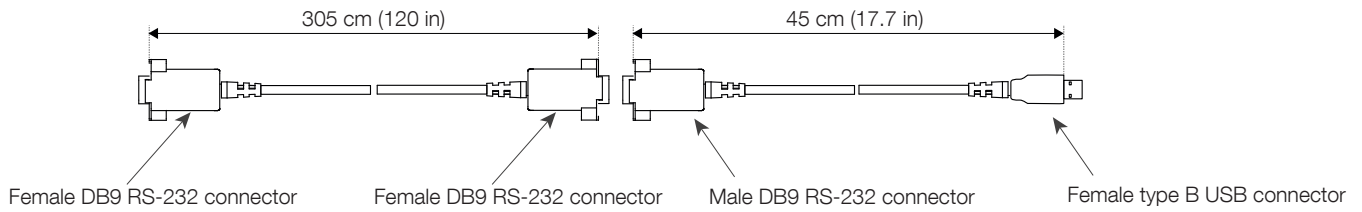

Reflector (REFL)

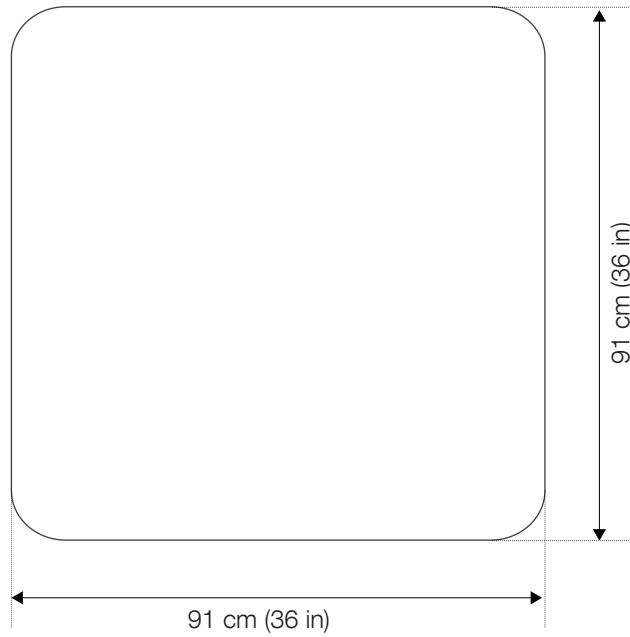

Battery pack (BPK)

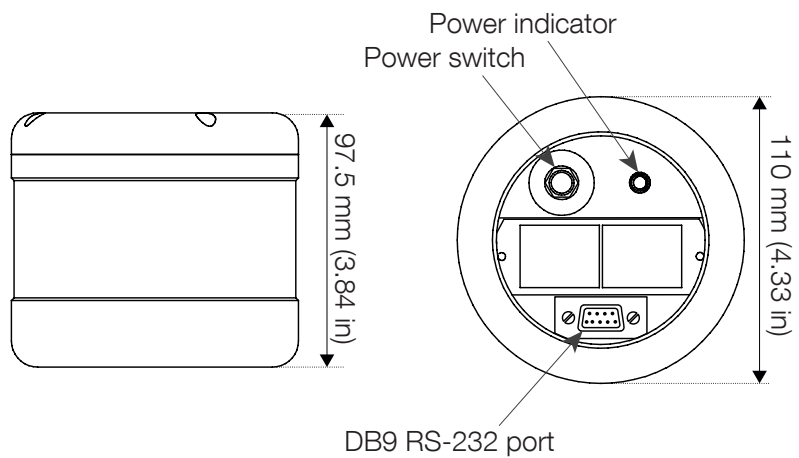

Ordering Information

Laser level sensor	LM80	A	B	C	D	E
Unit options						
Powder coated aluminum		A				
Powder coated aluminum with non condensing optics		AC				
Powder coated aluminum with 304 stainless steel dust tube		AP801				
Powder coated aluminum with non condensing optics and stainless steel dust tube		ACP801				
Powder coated aluminum with 304 stainless steel cooling tube		AP802				
Powder coated aluminum with non condensing optics and stainless cooling tube		ACP802				
Powder coated aluminum, non condensing optics and 4 in stainless triclover fitting		ACT804				
Aluminum positioning unit 150 m / 492 ft, dust tube, reflector & adjustable mounting		AP150				
Aluminum positioning unit and accessories with non condensing optics		ACP150				
316 Stainless steel		S				
316 Stainless steel with non condensing optics		SC				
316 Stainless steel with 304 stainless steel dust tube		SP801				
316 Stainless steel with non condensing optics and stainless steel dust tube		SCP801				
316 Stainless steel with 304 stainless steel cooling tube		SP802				
316 Stainless steel with non condensing optics and stainless cooling tube		SCP802				
Stainless positioning unit 150 m / 492 ft, dust tube, reflector & adjustable mounting		SP150				
Stainless positioning unit and accessories with non condensing optics		SCP150				
Approvals						
North America (Canada, USA) cCSAus Class 1 Div 2			CSA			
Factory Mutual FMus Class 1 Div 2			FM			
ATEX non sparking			ATEX			
IECEX non sparking			IECEX			
Metrology certification for Russia			RMET			
GOST-R non sparking and metrology certification for Russia			GR			
Extended warranty						
Extended warranty for 3 extra years - provides a total of 5 years warranty				EXW		
Replacement warranty - provides customer with new replacement unit instead of repair				RPW		
Accessories						
304 Stainless steel 4 in. / DN 100 mounting plate, bolt pattern as per class 150 and DN 100 / PN 10, no pressure rating					P804	
304 Stainless steel 6 in. / DN 150 mounting plate, bolt pattern as per class 150 and DN 150 / PN 10, no pressure rating					P806	
304 Stainless steel 4 in. raised face flange, bolt pattern as per class 150, no pressure rating					F804	
304 Stainless steel 6 in. raised face flange, bolt pattern as per class 150, no pressure rating					F806	
304 Stainless steel DN 100 flange, bolt pattern as per DN 100 / PN 10, no pressure rating					F810	
304 Stainless steel DN 150 flange, bolt pattern as per DN 150 / PN 10, no pressure rating					F815	
304 Stainless steel adjustable pivot mounting bracket					A800	
304 Stainless steel swivel mount flange					S800	
High pressure sight glass with spray ring cleaning system for high pressure/temperature applications						HPSG
Communication/configuration device and local display						LCD2
RS232 to USB cable for configuring LM80 using laptop or desktop computer						USBR
Set of 2 Ex cable glands with 1/2 in. NPT thread; size 0 / 8 mm and size 00 / 12 mm						GCK
Exd/e Flameproof imperial to metric adapter, 1/2 inch NPT to M20						GC1
Reflector plate 36 in. x 36 in. / 90 cm x 90 cm, for positioning applications						REFL
Battery pack for demo and mobility purposes						BPK
Gasket kit - contains 1 dust tube gasket and 1 flange gasket						G800

LM80

Laser level sensor

Software menu system

Communication with the LM80 takes place via the RS232 port located in the terminal compartment. Connect a computer with a standard USB port using the USBR cable and a terminal emulation programme such as PuTTY, or the handheld Communication Device (LCD2) directly to this port. Power up the LM80 and press the “EXIT” or “ENTER” button on the LCD2, or the PC’s “Spacebar” to enter the menu system.

The LM80 has advanced settings for more difficult applications. If the surface is unstable then the output can be smoothed by the rolling average “Buffer”. If material occasionally falls into the beam then the erroneous result can be removed and the correct level maintained by using the “Keep” setting. If the LM80 is being used in a dusty environment the incorrect readings can be eliminated using the “Dust” settings.

There are controls for the visible pointer, for the maximum range, for offsets, test facilities for the 4 - 20 mA and relay outputs, a choice of Metric or Imperial measuring units and settings for fail-safe conditions based on the NAMUR standards.



Menu item	Values / Options	LCD2	Description
Running mode	Distance measured and 4 - 20 mA current output displayed.		
4 - 20 mA Settings	A group of settings and options related to the 4 - 20 mA analog output.		
4 mA setpoint	0.00 m (ft) to max range	Yes	Sets the distance at which the analog output reads 4 mA
20 mA setpoint	0.00 m (ft) to max range	Yes	Sets the distance at which the analog output reads 20 mA
Fail-safe output	3.6 mA, 21.00 mA, last mA reading	Yes	Select the fail-safe 4 - 20 mA analog value to be output if there is no signal
Safety time (Fail-safe delay)	0 sec to 450 sec	Yes	Enter the time that the signal is lost before the fail-safe condition is output
4 - 20 mA test	4.00 mA, 12.00 mA, 20.00 mA	Yes	Select a value to output on the analog channel for test purposes
4 - 20 mA trim	4 mA reading 20 mA reading	No	This function recalibrates the laser sensor current output loop based on the readings entered at 4 mA and 20 mA
Relay settings	A group of settings and actions related to the relay outputs		
Relay A open	0.00 m (ft) to max range	Yes	Sets the distance at which the relay opens
Relay A closed	0.00 m (ft) to max range	Yes	Sets the distance at which the relay closes
Relay A test	open, closed	Yes	Toggles between relay open and relay closed
Relay B open	0.00 m (ft) to max range	Yes	Sets the distance at which the relay opens
Relay B closed	0.00 m (ft) to max range	Yes	Sets the distance at which the relay closes
Relay B test	open, closed	Yes	Toggles between relay open and relay closed
Application settings	A group of settings for filtering, smoothing and adjusting to application conditions		
Program	Standard, Light dust, Heavy dust, Position, Custom	Yes	Select predefined settings for selected application Use custom program for user defined application settings
Laser pointer	on off	No	Switch from service only mode (off - pointer comes on for 2 minutes at power up) to always on mode. All new LM80s are shipped set to off.
Range Blank	0.00 m (ft) to max range	No	If signal is lost this range is output instead of the fail safe setting
Resolution	High Low	No	High resolution is the normal setting, low resolution can be used for faster response at the expense of device resolution
Measuring units	meters, feet	Yes	Select measuring units; either meters or feet
Datum trim	-1.00 m (-3.28 ft) to 1.00 m (+3.28 ft)	Yes	Adjusts the zero datum point of the instrument. Factory default is from the front face of the flange (0.00 m).
Setpoint limit	0.00 m (ft) to ~150 m (~500 ft)	No	Adjusts the maximum range of the device. The firmware allows up to 2980 m but the hardware is only capable of about 150 m (500 ft).
Smoothing	Settings to adjust the filtering and smoothing of the output for the custom program		
Pause	0 sec to 255 sec	No	Sets the time between reading updates
Buffer	1 to 25	No	Sets the size of the rolling average buffer
Keep	1 to buffer	No	Sets the number of readings to keep in the averaging buffer, readings are removed starting with the shortest readings
Fill rate	0, 0.001 to 20000.000 units per minute	No	Sets the fastest filling speed expected, if zero the setting is not used. Otherwise, any sudden rise in level is smoothed by this setting.
Empty rate	0, 0.001 to 20000.000 units per minute	No	Sets the fastest emptying speed expected, if zero the setting is not used. Otherwise, any sudden drop in level is smoothed by this setting.
Environment	Normal Dust	No	"Normal" for most applications, uses fixed gain "Dust" uses variable gain to compensate for dusty conditions, is used in conjunction with fill rate

LM80

Laser level sensor

Red laser pointer

The LM80 ships with a visible red laser pointer (Class 3R) to enable easy and accurate alignment. Through the menu system, the pointer can be set to “On” or “Off”. When set to “Off” the pointer will only shine for 2 minutes at power on and when the unit is in the menu system. When set to “On”, the pointer will shine continuously when the unit is in the menu system. After exiting the menu system, the aiming pointer will flash to indicate that the unit is taking measurements in operational mode. The LM80 always ships from the factory with the pointer set to “Off”.

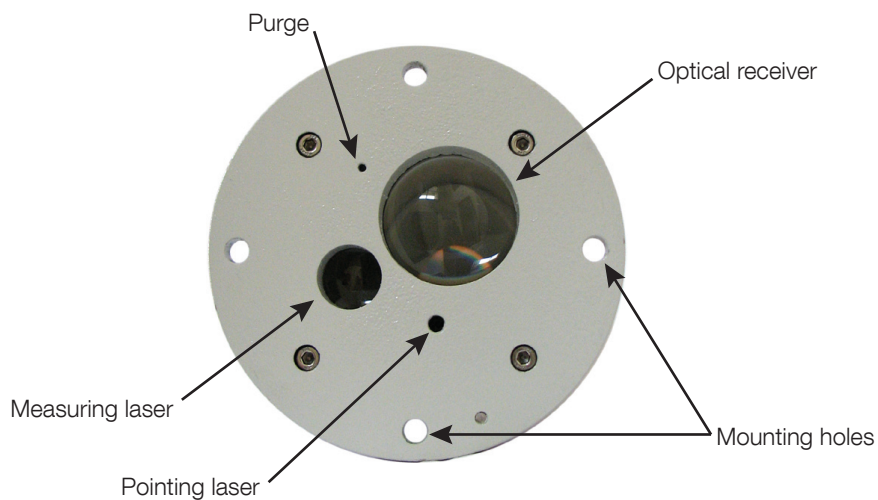

Mounting

The LM80 produces a narrow, straight measuring laser beam. The unit should be mounted facing towards the area to be measured with no obstacles directly in the beam path. Avoid mounting the instrument close to a stream of material that may fall in front of it. The LM80 has four 8.5 mm (0.33 in) diameter mounting holes on a 120 mm (4.72 in) bolt circle. The instrument can be bolted directly onto a flange or bracket. The LM80 may receive stronger signals in subdued lighting and dark conditions than it does in direct sunlight. Check the operation over the full range of conditions to be measured after installing.

Grounding

It is recommended to use a AWG 16 or 1.5 mm² wire for earth connection. For best results use a size 10 earth lug with a copper body terminal per ASTM B-152, and tin plating per MIL-T-10727, and a manufacturer AMP part No. 34112 or No. 34109. The earth wire terminated with the recommended earth lug must be connected to the designated terminal for this purpose. The internal earth screw is painted green, and the external earth screw is made of stainless steel.

Cables, wiring and routing

Always use shielded cables for power supply and signal. It is recommended to use a AWG16 or 1.5 mm² multi-core cable. The number of cores will depend upon the outputs required from the LM80. For a 4 - 20mA output, use a twisted pair shielded cable. Do not install the LM80 or route the signal cables in close proximity to high voltage electrical cables.

Dust management

In applications where dust may be present (even in very small quantities) it is recommended that the P801 dust tube accessory be used. The dust tube is a simple and effective device, designed to prevent dust settling on the lenses by creating a static airspace. When abundant dust is present the dust tube can additionally be purged with dry oil free air to further reduce any dust settling on the lens.

There are a number of advanced settings to improve performance when dust is present. The “Dust” setting in the “Environment” menu increases the dust penetration capabilities of the laser. In applications where the vessel may be loaded in batches and intermittent clouds of dust appear, a “Fill rate” may be entered to slow down the rate of response of the instrument.



LM80

Laser level sensor

Standard precautions

The LM80 is designed to withstand many industrial environmental conditions. However, a few precautions will ensure reliable operation of the unit for extended periods of time:

- Do not drop the instrument.
- Do not open the terminal compartment lid when an explosive dust or gas atmosphere may be present.
- Do not connect to the RS232 port when an explosive dust or gas atmosphere may be present.
- Do not expose the internal electronics to water or dirt.
- Do not install or connect with the power on.
- Use appropriate insulated lugs or ferrules for connections to the terminal block and grounding screws
- The flat stainless steel washer must be incorporated between the enclosure body and the lug to prevent corrosion from occurring.
- External transient protection of up to 40 % (44 V) of the maximum supply voltage ($32 \text{ V} \times 1.4 \leq 44 \text{ V}$) should be incorporated in the power supply line to the equipment when used in hazardous areas.
- Always keep the terminal compartment lid seal clean and lightly lubricated with Vaseline® Petroleum Jelly.
- Ensure that the terminal compartment lid is tight after connections have been made.
- If using cable glands, only use glands that have been suitably certified by a notified body for cable entry into the enclosure. If in doubt use cable glands supplied by ABB.
- Ensure that the cable glands are tight after connecting the external cable.
- Do not install conduit so that it can drain into the LM80 terminal compartment
- Remove dirt from the lenses with a clean, damp cloth only.
- Do not point the instrument at the sun.
- Avoid aiming the LM80 directly into the fill path of the vessel.
- For liquids always mount the laser to aim perpendicular to the liquid surface.

Notes

Contact us

ABB Analytical Measurements

Level Products

585 Charest Boulevard East, Suite 300
Québec (Québec) G1K 9H4
Canada

Tel: 1 800 858 3847

Tel: +1 418 877 8111

Fax: +1 418 877 2834

E-Mail: laserscanner.support@ca.abb.com

ABB US

18321 Swamp Road
Prairieville, LA 70769
USA

Tel: +1 225 673 6100

Fax: +1 225 637 2525

www.abb.com/level

Note

We reserve the right to make technical changes or modify the contents of this document without prior notice. With regard to purchase orders, the agreed particulars shall prevail. ABB does not accept any responsibility whatsoever for potential errors or possible lack of information in this document.

We reserve all rights in this document and in the subject matter and illustrations contained therein. Any reproduction, disclosure to third parties or utilization of its contents - in whole or in parts - is forbidden without prior written consent of ABB.

Copyright© 2012 ABB

All rights reserved

ABBCABOM-0363