

BA358E

Intrinsically safe 4/20mA loop-powered panel mounting Rate Totaliser

Issue 2

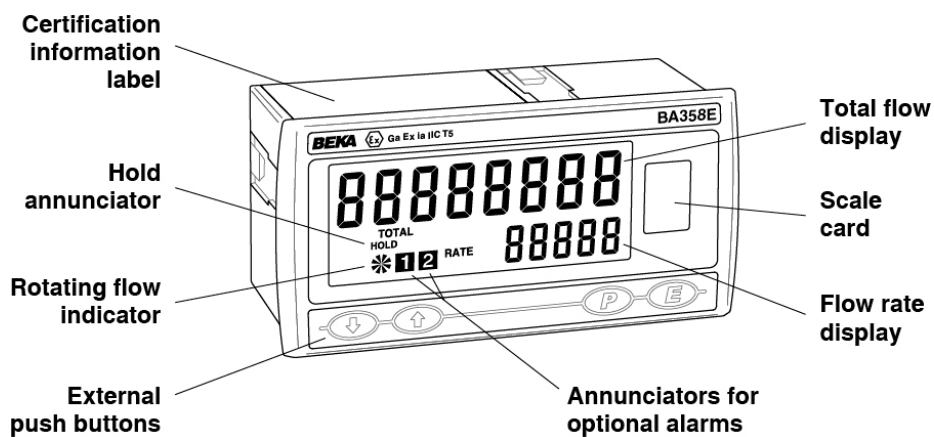

CONTENTS

1. Description

2. Operation

- 2.1 Controls
- 2.2 Displays

3. Intrinsic Safety Certification

- 3.1 ATEX gas certificate
- 3.2 Zones, gas groups & T rating
- 3.3 Special conditions for safe use
- 3.4 4/20mA input
- 3.5 Reset terminals
- 3.6 Certification label information

4. System Design for Hazardous Areas

- 4.1 Flow transmitter loops
- 4.2 Resetting the total display to zero
- 4.3 Remote indication

5. Installation

- 5.1 Location
- 5.2 EMC
- 5.3 Installation procedure
- 5.4 Scale card

6. Configuration and Calibration

- 6.1 Calibration structure
- 6.2 Accessing configuration & calibration functions.
- 6.3 Summary of configuration functions.
- 6.4 Rate totaliser function
- 6.5 Display resolution
- 6.6 Display update time
- 6.7 Upper display
- 6.8 Lower display
- 6.9 Position of decimal points
- 6.10 Calibration of rate display using an external current source.
- 6.11 Calibration of rate display using internal reference.
- 6.12 Clear grand total
- 6.13 Timebase
- 6.14 Function of **P** push button
- 6.15 Total scale factor
- 6.16 Clip off
- 6.17 Local reset of total and grand total displays.
- 6.18 Security code
- 6.19 Reset to factory defaults
- 6.20 Over-range

7. Lineariser

- 7.1 Calibration using external current source.
- 7.2 Calibration using internal reference
- 7.3 Error messages
- 7.4 Under and over-range
- 7.5 Default configuration

8. Calibration Examples

- 8.1 Using an external current source
- 8.2 Using the internal reference

9. Maintenance

- 9.1 Fault finding during commissioning
- 9.2 Fault finding after commissioning
- 9.3 Servicing
- 9.4 Routine maintenance
- 9.5 Guarantee
- 9.6 Customer comments

10. Accessories

- 10.1 Scale card
- 10.2 Tag information
- 10.3 Alarms
 - 10.3.1 Solid state output
 - 10.3.2 Intrinsic safety
 - 10.3.3 Configuration and adjustment
 - 10.3.4 Alarm enable
 - 10.3.5 Type of alarm
 - 10.3.6 Setpoint adjustment
 - 10.3.7 Alarm function
 - 10.3.8 Alarm output status
 - 10.3.9 Hysteresis
 - 10.3.10 Alarm delay
 - 10.3.11 Alarm silence time
 - 10.3.12 Flash display
 - 10.3.13 Access setpoint
 - 10.3.14 Adjusting alarm setpoints from display mode.
- 10.4 Display backlight
 - 10.4.1 Loop powered
 - 10.4.2 Separately powered

Appendix 1

ATEX dust certification

Appendix 2

IECEx certification

Appendix 2

FM and cFM certification

The BA358E is CE marked to show compliance with the European Explosive Atmospheres Directive 94/9/EC and the European EMC Directive 2004/108/EC

1. DESCRIPTION

The BA358E is a panel mounting intrinsically safe 4/20mA loop-powered Rate Totaliser primarily intended for use with flowmeters. The instrument simultaneously displays the rate of flow and the total flow in engineering units on two separate displays. The BA358E only introduces a 1.2V drop, which allows it to be installed into almost any 4/20mA flow loop. No additional power supply or battery is required.

The rate totaliser has been certified intrinsically safe for use in gas and dust hazardous areas by Notified Body Intertek Testing and Certification Ltd and complies with the European ATEX Directive 94/9/EC. The EC-Type Examination certificate specifies that under fault conditions the output voltage, current and power at the 4/20mA input terminals will not exceed those specified for *simple apparatus* in Clause 5.7 of EN 60079-11, which simplifies installation and documentation.

For international applications the BA358E has IECEx, FM and cFM certification which are described in Appendixes 2 and 3.

2. OPERATION

Fig 1 shows a simplified block diagram of a BA358E. The 4/20mA input current flows through resistor R1 and forward biased diode D1. The voltage developed across D1, which is relatively constant, is multiplied by a switch mode power supply and used to power the instrument. The voltage developed across R1, which is proportional to the 4/20mA input current, provides the input signal for the analogue to digital converter.

Each time a 4/20mA current is applied to the instrument, initialisation is performed. After a short delay the following display sequence occurs which takes about twelve seconds:

All segments of the display are activated

Loading message displayed

Configuration message displayed

Model and firmware version displayed

The BA358E Rate Totaliser starts functioning, using configuration information stored in the instrument's permanent memory. Unless total and grand total displays have been reset to zero, new flow will be added to the existing totals.

If the 4/20mA current is disconnected during operation the latest total and grand total are stored in permanent memory.

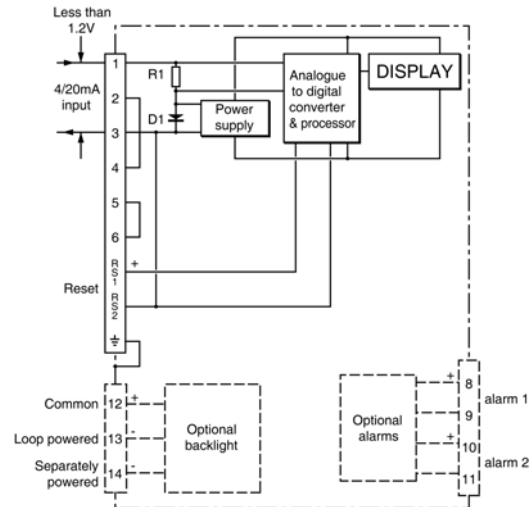

Fig 1 Simplified block diagram of BA358E

2.1 Controls

The BA358E is controlled and calibrated via four front panel push buttons located below the display. In the operating mode i.e. when the instrument is displaying rate and total flow the push button functions are:

Summary of Push Button Functions

- | | |
|------------|----------------------------------------------------------------------------------------------------|
| P | Displays input current in mA or as a percentage of span. Modified when optional alarms are fitted. |
| ▼ | Shows rate display calibration at 4mA input. |
| ▲ | Shows rate display calibration at 20mA input. |
| E | Shows time since instrument was powered or total display was reset. |
| E+▼ | Grand total – displays least significant 8 digits |
| E+▲ | Grand total – displays most significant 8 digits. |
| ▼+▲ | Resets total display
Configurable function |
| P+▼ | Shows firmware version |
| P+▲ | Alarm setpoint access
Configurable function |
| P+E | Access to configuration menu |

Full Description of Push Button Functions

- P** While this button is pushed the rate display will show the input current in mA, or as a percentage of the instrument span depending upon how the instrument has been configured. When the button is released the normal display in engineering units will return. The function of this push button is modified when optional alarms are fitted to the instrument.
- ▼** While this button is pushed the instrument will show the calibrated rate display with 4mA* input - usually zero for flow applications. When the button is released the flow rate will again be displayed.
- ▲** While this button is pushed the instrument will show the calibrated rate display with 20mA* input. When the button is released the flow rate will again be displayed.
- E** While this button is pushed the Rate Totaliser will display the time in hours, minutes and seconds since the instrument was powered or the total display was reset. The elapsed time is not saved when power is removed.
- E+▼** While these buttons are pushed the total display will show the least significant eight digits of the grand total, and the grand total annunciator will be activated.
- E+▲** While these two buttons are pushed the total display will show the most significant eight digits of the grand total and the grand total annunciator will be activated.
After the two buttons have been pushed for ten seconds 'CLr no' with the 'no' flashing will be displayed. If no action is required, pressing **E** will return the instrument to the operating mode. Operating the **▼** or **▲** button will toggle the display to 'CLr YES' with 'YES' flashing, operating the **E** button will then clear the grand total and 'Gt CLrd' will be displayed to confirm the operation. The instrument will then automatically return to the operating mode.
Selectable function in the configuration menu. See section 6.17

Note: Totalisation will continue until 'CLr no' or 'CLr YE5' are displayed.

- ▼+▲** Resets the total display to zero when these two push buttons are operated simultaneously. Selectable function in the configuration menu. See section 6.17
- P+▼** Rate Totaliser displays firmware version.
- P+▲** Provides direct access to the alarm setpoints when optional alarms are fitted to the Rate Totaliser and the 'AC5P' access setpoints in display mode function has been enabled. See section 10.2.13
- P+E** Provides access to the configuration menu via optional security code.

Note: * If the Rate Totaliser has been calibrated using the CAL function, calibration points may not be 4 and 20mA.

2.2 Displays

The BA358E has two digital displays and associated annunciators, plus a flow indicator as shown on page 1.

Lower display Shows the flow rate on the five digit plus sign 12mm high display.

Upper display Shows the total flow on the eight digit (seven with negative sign) 18mm high display which may be reset to zero by operating the **▼+▲** instrument push buttons or by an external contact closure.

The rate and total displays may be interchanged, see section 6.7

Flow indicator This disc on the lower left hand side of the display rotates when the input current exceeds 4.000mA, indicating that flow is being detected by the Rate Totaliser. For bi-directional flow, the disc rotates when flow exceeds $\pm 0.05\%$ of span.

Annunciators

Reset Activated when total display is reset to zero by operating the **▼+▲** buttons simultaneously or by connecting the reset terminals together.

Hold Activated when flow rate falls below the clip-off value and totalisation is

inhibited.

Grand Total Is a 16 digit (15 digit with negative sign) number which is not zeroed when the total display is zeroed. The Grand Total is viewed from the operating mode as two eight digit numbers, it may be reset to zero from within the configuration menu or from the operating mode.

3. INTRINSIC SAFETY CERTIFICATION

The BA358E rate totaliser has ATEX and IECEx gas and dust certification. This section of the instruction manual describes ATEX gas certification. ATEX dust, IECEx and other approvals are each described in separate appendixes to this manual.

3.1 ATEX gas certification

Notified Body Intertek Testing and Certification Ltd have issued the BA358E with an EC-Type Examination Certificate number ITS11ATEX27254X. This confirms compliance with harmonised European standards and it has been used to confirm compliance with the European ATEX Directive for Group II, Category 1G equipment, Ex ia IIC T5 Ga Ta = -40 to +70°C. The Rate Totaliser bears the community mark and subject to local codes of practice may be installed in any of the European Economic Area (EEA) member countries. ATEX certificates are also acceptable for installations in Switzerland.

This section of the instruction manual describes ATEX installations in explosive gas atmospheres conforming with EN60079-14 Electrical Installations in Hazardous Areas. When designing systems for installation outside the UK the local Code of Practice should be consulted.

3.2 Zones, gas groups and T rating

The BA358E Rate Totaliser has been certified Ex ia IIC T5. When connected to a suitable system it may be installed in:

- Zone 0 explosive gas air mixture continuously present.
- Zone 1 explosive gas air mixture likely to occur in normal operation.
- Zone 2 explosive gas air mixture not likely to occur, and if it does will only exist for a short time.

Be used with gases in groups:

- Group A propane
- Group B ethylene
- Group C hydrogen

Having a temperature classification of:

T1	450°C
T2	300°C
T3	200°C
T4	135°C
T5	100°C

At ambient temperatures between -40 and +70°C.

Note: The specified operating temperature of the BA358E is -20 to +70°C. At temperatures below -20°C the instrument will continue to totalise but the display will not function.

This allows the Rate Totaliser to be installed in all gas Zones and to be used with most common industrial gases.

3.3 Special conditions for safe use

The ATEX certificate has an 'X' suffix indicating that special conditions apply for installations in IIIC conductive dust atmospheres. No special conditions apply for installations in gas or in IIIA and IIIB dust atmospheres. See Appendix 1 for information about use in dust atmospheres.

3.4 4/20mA input

The input safety parameters for the 4/20mA input, terminals 1 and 3 are:

U _i	=	30V dc
I _i	=	200mA
P _i	=	0.84W

The maximum equivalent capacitance and inductance between the two 4/20mA input terminals 1 and 3 is:

C _i	=	13nF
L _i	=	16μH

The maximum permitted loop cable parameters can be calculated by adding these figures to C_i and L_i of other instruments in the loop and subtracting the totals from the maximum cable capacitance C_o and cable inductance L_o permitted for the Zener barrier or galvanic isolator powering the loop.

Although the BA358E does not comply with the requirements for *simple apparatus*, the EC-Type Examination Certificate states that for intrinsic safety considerations, under fault conditions the output voltage, current and power at terminals 1 & 3 will not exceed those specified by clause 5.7 of EN 60079-11 for *simple apparatus*. This simplifies the application and intrinsic safety documentation for a loop into which the BA358E is connected. Apart from C_i, the affect of the Rate Totaliser may be ignored when assessing loop safety.

3.5 Reset terminals

The BA358E total display may be reset to zero by connecting the reset terminals RS1 and RS2 together. These two terminals have the following input and output intrinsic safety parameters:

$$\begin{aligned} U_i &= 30\text{V dc} \\ I_i &= 200\text{mA dc} \\ P_i &= 0.84\text{W} \\ \\ U_o &= 6\text{V dc} \\ I_o &= 2.5\text{mA dc} \\ P_o &= 3.75\text{mW} \end{aligned}$$

The maximum equivalent capacitance and inductance between them is:

$$\begin{aligned} C_i &= 13\text{nF} \\ L_i &= 8\mu\text{H} \end{aligned}$$

The total display may be reset to zero from within the hazardous area by any mechanically operated switch connected directly to terminals RS1 and RS2. Alternatively, the BA358E may be configured so that the total display is reset to zero when the ▲ and ▼ push buttons are operated simultaneously for two seconds.

To reset the total display from the safe area a Zener barrier or intrinsically safe relay is required to transfer the contact closure into the hazardous area. Almost any intrinsically safe relay with certification permitting the contacts to be connected to equipment in the hazardous area may be used. Alternatively, a positive polarity Zener barrier with intrinsic safety parameters equal to or less than the input parameters of the reset terminals may be used as shown in Fig 3A. The total resistance of the barrier, switch and interconnecting wiring must be less than 1kΩ.

Note:

The negative reset terminal RS2 is internally connected to the negative 4/20mA input terminal 3.

3.6 Certification label information

The certification label is fitted in a recess on the top outer surface of the instrument enclosure. It shows the ATEX certification information and BEKA associates' name and location. Non European certification information may also be shown.



BA358E certification label

4. SYSTEM DESIGN FOR HAZARDOUS AREA

4.1 Flow transmitter loops

A BA358E Rate Totaliser may be connected in series with almost any intrinsically safe 4/20mA flow loop and calibrated to display the rate of flow and total flow. There are three basic design requirements:

1. The intrinsic safety output parameters of the 4/20mA loop, which are defined by the Zener barrier or galvanic isolator powering the loop, must be equal to or less than:

$$\begin{aligned} U_o &= 30V \text{ dc} \\ I_o &= 200mA \\ P_o &= 0.84W \end{aligned}$$

2. The maximum permitted cable capacitance of the loop must be reduced by 13nF. The maximum permitted cable inductance is not reduced by the inclusion of the BA358E.
3. The loop must be able to tolerate the additional 1.2V required to operate the Rate Totaliser. When fitted with an optional backlight this increases to 5.0V if the backlight is loop powered. See 10.3.1

Figs 2a and 2b illustrates typical applications in which a Rate Totaliser is connected in series with a 2-wire flow transmitter powered by a Zener barrier and alternatively by a galvanic isolator.

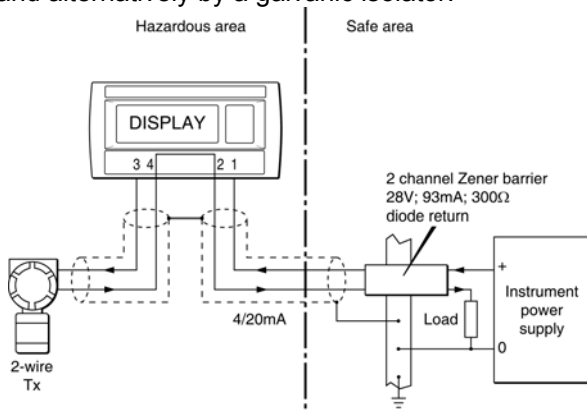

Fig 2a Loop powered by a Zener barrier

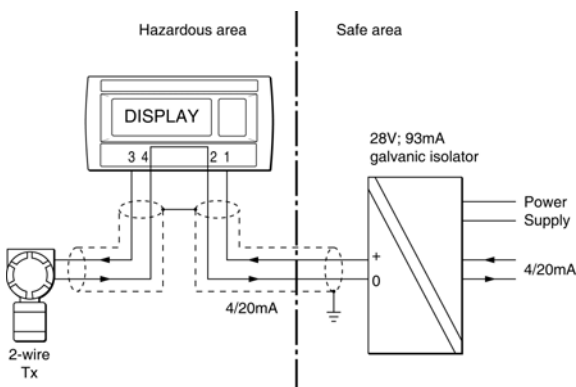

Fig 2b Loop powered by a galvanic isolator

4.2 Resetting the total display to zero

The BA358E total display may be reset to zero by momentarily connecting the reset terminals RS1 and RS2 together with a resistance of less than 1kΩ. Within the hazardous area in which the BA358E is located this may be achieved with a manually activated industrial push button as shown in Fig 3b.

The push button switch and the wiring connecting it to the Rate Totaliser must comply with the requirements for simple apparatus specified in Clause 5.7 of EN60079-11. i.e. be able to withstand a 500V rms insulation test for one minute. The switch button should comply with the electrostatic requirements specified by Clause 7 of EN60079-0 and material composition defined in Clause 8.

If it is required to reset the total display from the safe area a Zener barrier, galvanic isolator or intrinsically safe relay must be used to transfer the contact closure into the hazardous area. Fig 3a shows how a single channel positive polarity Zener barrier may be used.

Note:

The negative reset terminal RS2 is internally connected to the negative 4/20mA input terminal 3.

4.3 Remote indication

A BA358E may be driven via an intrinsically safe interface from a 4/20mA safe area signal to provide a remote indication of rate and total flow within a hazardous area. The type of interface is not critical, either a Zener barrier or a galvanic isolator may be used, providing that U_i , I_i and P_i of the BA358E 4/20mA input are not exceeded.

If one side of the 4/20mA current loop may be earthed, a single channel Zener barrier provides the lowest cost protection. If the 4/20mA signal is not isolated, then two Zener barriers, a two channel Zener barrier or a galvanic isolator must be used.

When the hazard is a IIC gas and two single channel Zener barriers or a two channel Zener barrier are used, only one barrier or channel may be a 28V 93mA device. A 10V 50Ω or diode return barrier may be used for the second channel to form a safe combination.

Again it is necessary to ensure that the voltage capability of the 4/20mA signal is sufficient to drive the BA358E Rate Totaliser plus the voltage drop introduced by the intrinsically safe interface. Figs 3a, 3b and 3c show the alternative circuits which may be used.

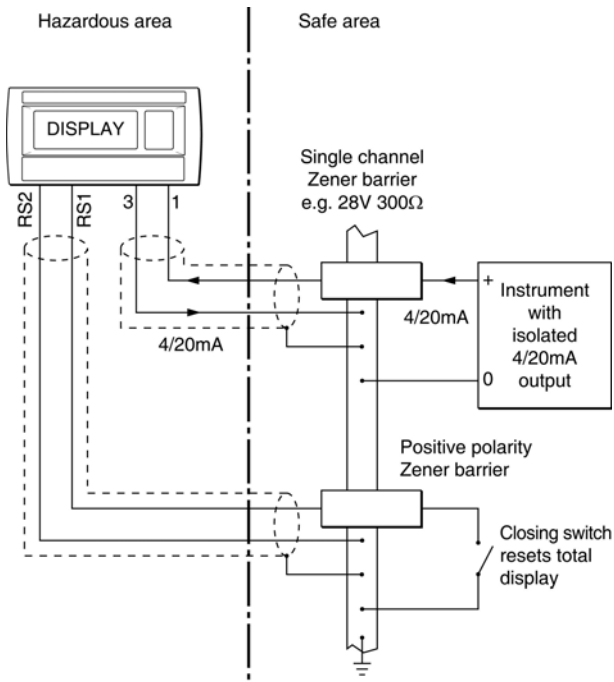

Fig 3a Simplest circuit with one side of 20mA current loop connected to earth. Also illustrates resetting from safe area.

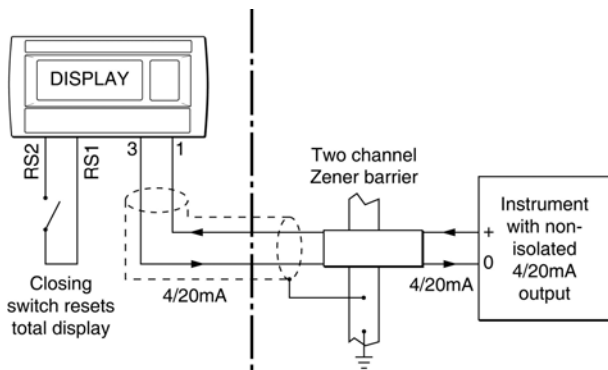

Fig 3b Two Zener barrier channels are required if the 4/20mA current loop can't be earthed at the barrier busbar. Also shows optional resetting from hazardous area

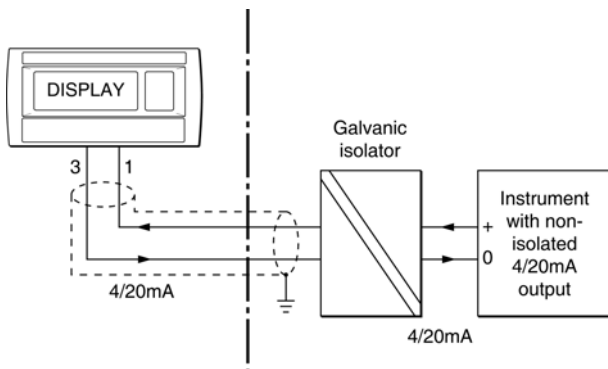

Fig 3c Galvanic isolator can be used with any 4/20mA current loop.

5. INSTALLATION

5.1 Location

The BA358E Rate Toylslider has a robust glass reinforced modified PPO enclosure with a toughened glass window. The front of the Rate Totaliser has IP66 protection and a gasket seals the joint between the instrument enclosure and the panel. The rear of the instrument has IP20 protection.

The Rate Totaliser will function and is certified intrinsically safe at ambient temperatures between -40°C and +70°C, but the display only functions at ambient temperatures between -20°C and +70°C.

Fig 4 shows the overall BA358E Rate Totaliser dimensions together with the recommended panel cut-out dimensions. To achieve an IP66 seal between the instrument enclosure and the instrument panel the smaller tolerance aperture should be used, and the Rate Totaliser should be secured with four panel mounting clamps.

Although the Rate Totaliser front panel provides IP66 protection it should be shielded from direct sunlight and severe weather conditions.

5.2 EMC

The BA358E Rate Totaliser complies with the requirements of the European EMC Directive 2004/108/EC. For specified immunity all wiring should be in screened twisted pairs, with the screens earthed at one point within the safe area.

Cut-out dimensions

Recommended for all installations.

Mandatory to achieve an IP66 seal between the instrument and the panel
136 +0.5/-0.0 x 66.2 +0.5/-0.0

Note: Four panel mounting clamps required to achieve an IP66 seal

DIN 43 700

138.0 +1.0/ -0.0 x 68 +0.7 -0.0

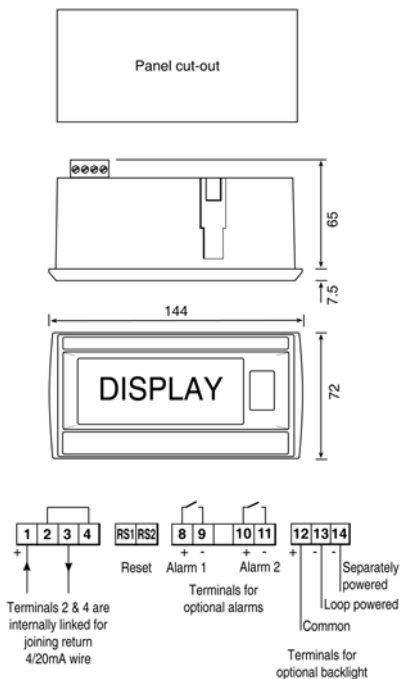

Fig 4 BA358E dimensions

5.3 Installation Procedure

- Cut the specified aperture in the panel. To achieve an IP66 seal between the instrument enclosure and the instrument panel the aperture must have the tighter tolerances specified in Fig 4.
- Slide the gasket over the body of the Rate Totaliser before inserting the instrument into the panel aperture.
- Firstly ensure that all the panel mounting clamps are closed by turning the knurled screws fully anti clockwise until the two pips in the clamp foot align with holes in the clamp body.
- Place a clamp in the recess on each side of the Rate Totaliser, pulling gently to slide it onto the dovetail as shown in Fig 5. Push the knurled screw slightly forward to engage the thread and tighten by turning clockwise until it is just finger tight. When all four clamps are fitted ensure that the gasket behind the front panel bezel is correctly positioned before fully tightening the clamps to secure the instrument. The maximum recommended clamp tightening torque is 22cNm (1.95 lbf in) which is approximately equivalent to finger-tight plus one half turn. **Do not over tighten.**
- Connect the panel wiring to the rear terminal block(s) as shown in Figs 4. To simplify installation, the terminals are removable so that the panel wiring can be completed before the instrument is installed.

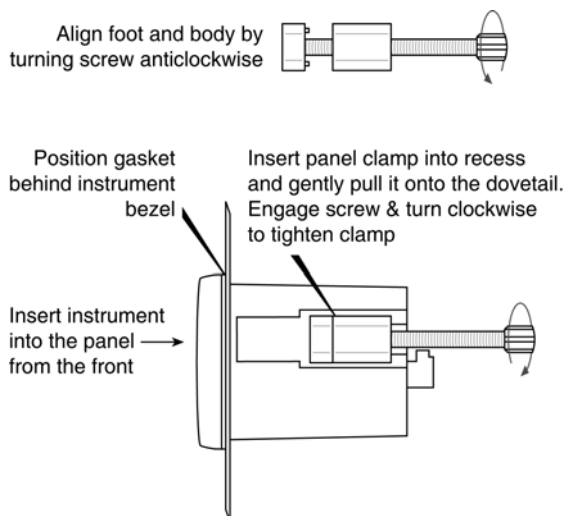

Fig 5 Fitting panel mounting clamps

5.4 Scale card

The Rate Totaliser's units of measurement are shown on a printed scale card in a window at the right hand side of the display. The scale card is mounted on a flexible strip that is inserted into a slot at the rear of the instrument as shown in Fig 6. Thus the scale card can easily be changed without removing the BA358E Rate Totaliser from the panel or opening the instrument enclosure.

New instruments are supplied with a printed scale card showing the requested units of measurement, if this information is not supplied when the Rate Totaliser is ordered a blank card will be fitted.

A pack of self-adhesive scale cards printed with common units of measurement is available as an accessory from BEKA associates. Custom printed scale cards can also be supplied.

To change a scale card, unclip the protruding end of the flexible strip by gently pushing it upwards and pulling it out of the enclosure. Peel the existing scale card from the flexible strip and replace it with a new printed card, which should be aligned as shown below. Do not fit a new scale card on top of an existing card.

Install the new scale card by gently pushing the flexible strip into the slot at the rear of the instrument, when it reaches the internal end-stop secure it by pushing the end of the flexible strip downwards so that the tapered section is held by the rear panel.

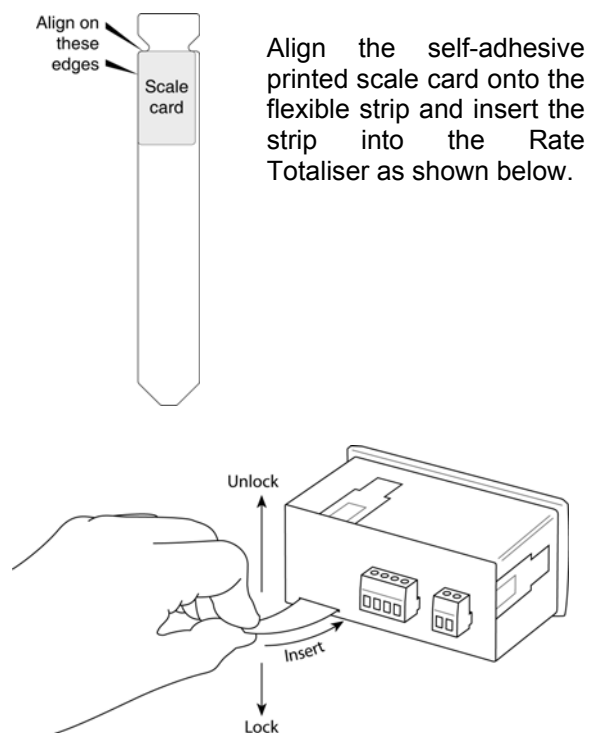

Fig 6 Inserting flexible strip carrying scale card into slot at the rear of Rate Totaliser.

6. CONFIGURATION AND CALIBRATION

The BA358E is configured and calibrated via the four front panel push buttons that are located below the display.

All the configuration functions are contained in an easy to use menu that is shown diagrammatically in Fig 8. Each function is summarised in section 6.3 which includes references to more detailed information. Although this simple menu driven system enables most adjustments to be made without repeated reference to this manual, it is recommended that at least the summary of the configurable functions in section 6.3 is read before attempting configuration or recalibration.

When the instrument is fitted with alarms, the basic menu is expanded to include the alarm functions that are described in section 10.3 of this manual.

Note:

While the instrument is being configured or calibrated totalisation is suspended, any flow occurring during this time will not be recorded.

6.1 Calibration structure

Fig 7 shows the BA358E calibration structure. The 4/20mA input current, which in flow applications represents flow rate, is usually displayed on the five digit plus sign lower display. If necessary this flow signal may be linearised using the square root extractor or the 16 segment lineariser which are selectable in the instrument's 'FunC' sub-menu. The rate display may then be calibrated using the 'CAL' or '5Et' functions to show the flow rate in the required linear engineering units. Both the zero (display at 4mA) and the span (display at 20mA) are adjustable, although for unidirectional flow application the display at 4mA is usually zero. The position of the decimal point in the rate display is defined by the 'dP' function. To simplify calibration the BA358E uses floating point arithmetic, moving the rate display decimal point position will therefore affect totalisation.

For bi-directional flow applications zero flow will be represented by an input current other than 4mA. When one of the two bi-direction functions in the 'FunC' sub-menu is selected, input currents below that representing zero flow will be shown as a negative flow rate and the total flow display will count down. For input currents above that representing zero flow will be shown as a positive flow rate and the total flow display will count up.

The BA358E total display is calculated from the rate display using two serial factors: the timebase 't-bA5E' and the total scaling factor '5CALE-t'. The timebase divides the rate display according to whether the rate display represents flow per

second, per minute or per hour. The total scaling factor '5CALE-t' is a wide range configurable dividing factor allowing the rate and total displays to be in different units.

The total is calculated and the display updated once per second, which defines the resolution of the total flow display. When total alarms are used for batching applications, this resolution may define the accuracy of the system.

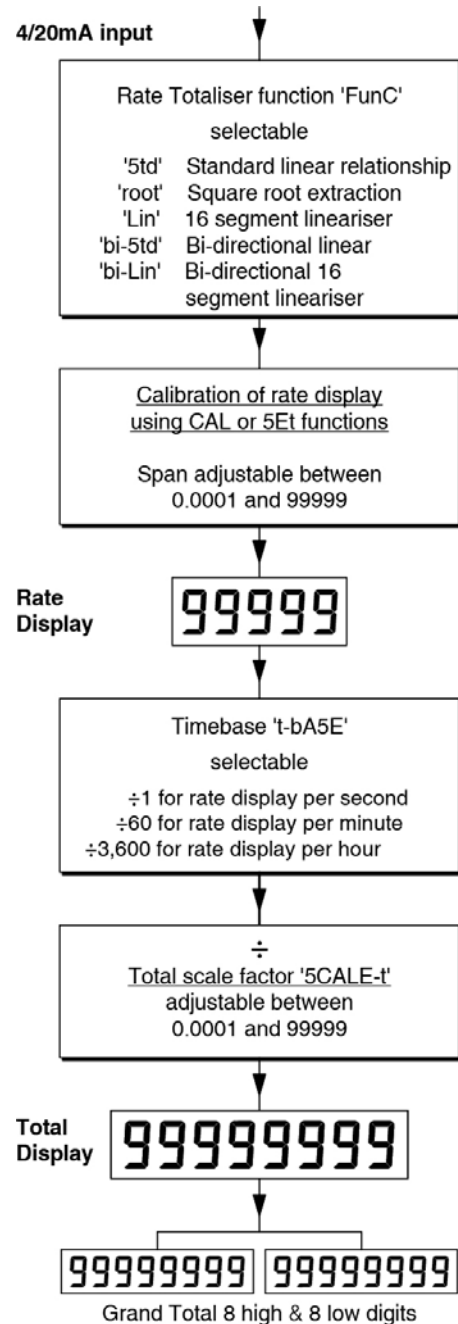

Fig 7 Calibration structure

6.2 Accessing the configuration and calibrations functions.

Throughout this manual push buttons are shown as **P**, **E**, **▼** or **▲**, and legends displayed by the Rate Totaliser are shown within inverted commas e.g. 'CAL' and 'ALr2'.

Access to the configuration menu is obtained by operating the **P** and **E** push buttons simultaneously. If the Rate Totaliser's security code is set to the default 0000 the first parameter 'FunC' will be displayed. If a security code other than the default code 0000 has already been entered, the Rate Totaliser will display 'CodE'. Pressing the **P** button will clear this prompt allowing each digit of the code to be entered using the **▲** and **▼** push buttons and the **P** button to move control to the next digit. When the correct four digit code has been entered pressing **E** will cause the first parameter 'FunC' to be displayed. If the code is incorrect, or a button is not pressed within twenty seconds, the Rate Totaliser will automatically return to the display mode.

Once within the configuration menu the required parameter can be reached by scrolling through the menu using the **▲** and **▼** push buttons as shown in Fig 8. When returning to the display mode following recalibration or a change to any function, the Rate Totaliser will display 'dAtA' followed by 'SAVE' while the new information is stored in non-volatile memory.

All new Rate Totalisers are supplied calibrated as requested at the time of ordering. If calibration is not requested, Rate Totalisers will be supplied with the following default configuration:

Default Configuration

Access code 'CodE'	0000
Function 'FunC'	'5td' Linear
Rate display at 4mA 'Zero'	0.00
Rate display at 20mA '5Pan'	100.00
Resolution 'rE5n'	1 digit
P button in display mode 'C—P'	%
Local reset of total 't-rE5Et'	off
Local reset of grand total 'Gt-rE5Et'	off
Clip off 'CLIP oFF'	000.00
Timebase 't-bA5E'	1
Total scale factor '5CALE-t'	1.00
Upper display 'di5P-1'	Total
Update time 'uPdAtE'	1

6.3 Summary of configuration functions

This section summarises each of the main configuration functions and includes a cross reference to a more detailed description. Fig 8 illustrates the location of each function within the configuration menu. The lineariser and the optional factory fitted alarms are described separately in sections 7 and 10.2 of this manual.

Display	Summary of function
'FunC'	<p>Rate Totaliser function Defines the relationship between the 4/20mA input current and the instruments rate display. For uni-directional flow may be set to:</p> <p>'5td' Standard linear relationship 'root' Square root extraction 'Lin' 16 segment adjustable lineariser – see section 7.</p> <p>For bi-directional flow may be set to:</p> <p>'bi-5td' Standard linear relationship 'bi-Lin' 16 segment adjustable lineariser – see section 7. See section 6.4</p>
'rE5n'	<p>Display resolution Defines the resolution of the least significant rate display digit. May be set to '1', '2', '5' or '10' digits. See section 6.5</p>
'uPdAtE'	<p>Update Defines the interval between updates. May be set to '1', '2', '3', '4' or '5' seconds. See section 6.6</p>
'di5P-1'	<p>Upper display Defines whether 'totAL' or 'rAtE' is shown on the upper eight digit display. See section 6.7</p>
'di5P-2'	<p>Lower display Turns lower six digit display 'on' or 'oFF'. See section 6.8</p>
'dP'	<p>Decimal points Positions the decimal point in the 'rAtE' and 'totAL' displays. See section 6.9</p>

Display	Summary of function	Display	Summary of function
'CAL'	<p>Calibration of the rate display using an external current source. Enables the zero and span of the rate display to be adjusted using an external current source such as a calibrator. When used with an accurate traceable calibrator this is the preferred method of calibration. See section 6.10</p>	'5CALE-t'	<p>Total scale factor Defines the arithmetic relationship between the rate and total displays. May be adjusted between 0.0001 and 99999</p> $5CALE-t = \frac{\text{Units of rate display}}{\text{Units of total display}}$ <p>To calculate 5CALE-t the required units of measurement for the total display must be converted to the units of measurement used for the rate display. See section 6.15 and Fig 6.</p>
'5Et'	<p>Calibration of rate display using internal references. Enables the zero and span of the rate display to be adjusted without the need for an accurate input current or disconnection from the 4/20mA loop. See section 6.11</p>	'CLiP-oFF'	<p>Clip off To prevent the totalisation of very low flow rates, this function defines the flow rate below which totalisation is inhibited and the 'HOLD' annunciator activated. See section 6.16</p>
'Clr.Gtot'	<p>Clear grand total Resets the sixteen digit grand total to zero when 'Clr.YES' is selected and '5urE' is entered digit by digit to confirm the instruction. Note: Once cleared a grand total can not be recovered. See section 6.12</p>	'LoC.r5Et'	<p>Local reset of total and grand total. Contains two independent functions 't-rE5Et' and 'Gt-rE5Et'.</p> <p>'t-rE5Et' enables the total display to be reset to zero when ▼ and ▲ push buttons are operated simultaneously for more than 2 seconds.</p> <p>'Gt-rE5Et' enables the grand total to be reset to zero when E and ▲ push buttons are operated simultaneously for more than 10 seconds. See section 6.17</p>
't-bA5E'	<p>Timebase Selectable divisor to display flow rate in units per second, per minute or per hour. Select: 'tb-01' for flow / second 'tb-60' for flow / minute 'tb-3600' for flow / hour See section 6.13</p>	'CodE'	<p>Security code Defines a four digit numeric code that must be entered to gain access to the configuration menu. Default code 0000 disables this security function and allows unrestricted access to all conditioning functions. See section 6.18</p>
'C - - P'	<p>Function of P push button The Rate Totaliser may be configured to display the input current in milliamps, or the input current as a percentage of the 4/20mA input when the P push button is operated in the display mode. Select: 'PC' % of 4/20mA input '4-20' Current in mA</p> <p>Note: 'PC' is not available with lineariser. See section 6.14</p>		

Display	Summary of function				
'r5Et'	<p data-bbox="323 255 759 311">Reset Rate Totaliser to factory defaults.</p> <p data-bbox="323 315 759 342">Contains two sub-functions,</p> <p data-bbox="323 347 759 374">Select:</p> <table data-bbox="379 378 759 591"><tr><td data-bbox="379 378 459 405">'ConF'</td><td data-bbox="496 378 759 465">Returns instrument to default configuration shown in section 6.2</td></tr><tr><td data-bbox="379 501 459 528">'LTab'</td><td data-bbox="496 501 759 589">Returns lineariser to defaults shown in section 7.5</td></tr></table> <p data-bbox="323 624 759 712">Both instructions must be confirmed by entering '5urE' digit by digit before they will be executed.</p> <p data-bbox="323 716 759 741">See section 6.19</p>	'ConF'	Returns instrument to default configuration shown in section 6.2	'LTab'	Returns lineariser to defaults shown in section 7.5
'ConF'	Returns instrument to default configuration shown in section 6.2				
'LTab'	Returns lineariser to defaults shown in section 7.5				

6.4 Rate Totaliser function: 'FunC'

This configuration function defines the relationship between the Rate Totaliser's 4/20mA input current and the instruments's rate display. Three alternatives are available for uni-direction flow and two for bi-direction flow.

For uni-directional flow:

- '5td' Standard linear relationship
- 'root' Square root extraction
- 'Lin' 16 segment adjustable lineariser

For bi-directional flow:

- 'bi-5td' Standard linear relationship
- 'bi-Lin' 16 segment adjustable lineariser

To reveal the existing instrument function, select 'FunC' from the configuration menu and press **P**. If the function is set as required, press **E** to return to the menu, or press the **▲** or **▼** button to change the setting, followed by the **E** button to return to the configuration menu.

'5td' Linear

Provides a linear relationship between the 4/20mA Rate Totaliser input current and the instruments rate display for uni-directional flow.

'root' Square root extraction

Primarily intended to linearise the square law 4/20mA output from differential flowmeters.

For reference, the following table shows the output current from a non-linearised differential flowmeter.

% of full flow	Current output mA
2.5	4.01
10.0	4.16
25.0	5.00
50.0	8.00
75.0	13.00
100.0	20.00

When the root function is selected the Rate Totaliser will display flow in linear units for uni-directional flow.

'Lin' 16 segment adjustable lineariser

May be adjusted to compensate for flowmeter non-linearity with uni-directional flow. Use of the lineariser is described in section 7 of this instruction manual.

'bi-5td' Linear

Provides a linear relationship between the 4/20mA Rate Totaliser input current and the instruments rate display for bi-directional flow.

'bi-Lin' 16 segment adjustable lineariser

May be adjusted to compensate for flowmeter non-linearity with bi-directional flow. Use of the lineariser is described in section 7 of this instruction manual.

6.5 Display resolution: rE5n

This function defines the resolution of the least significant display digit of the rate display. Decreasing the display resolution can improve the readability of a noisy signal. Select 'rE5n' from the menu and press **P** which will reveal the current display resolution. To change the resolution press the **▲** or **▼** button to select 1, 2, 5 or 10 digits, followed by the **E** button to enter the selection and return to the configuration menu.

6.6 Display update time: 'uPdAtE'

If the rate display is likely to change rapidly, extending the time between display updates will make the display easier to read. Five different intervals between readings are selectable, 1, 2, 3, 4 or 5 seconds.

To reveal the existing update time select 'uPdAtE' from the configuration menu and press **P**. If the time is set as required, press **E** to return to the menu, or press the **▲** or **▼** button to change the time, followed by the **E** button to return to the configuration menu.

This function only changes the interval between successive display updates, it does not change the instrument accuracy.

6.7 Upper display: 'di5P-1'

The Rate Totaliser has two numeric displays:

Upper

8 digit 18mm high intended for showing total flow display range -9999999 to 99999999

Lower

6 digits 12mm high intended for showing flow rate display range -99999 to 99999

This function interchanges the rate and total displays when the flow rate is required to be predominant, resulting in a 5 digit plus sign upper rate display and a 6 digit lower total display, or 5 digits plus sign when negative.

To reveal the existing upper display function select 'di5P-1' from the configuration menu and press **P**. If set as required, press **E** to return to the configuration menu, or press the **▲** or **▼** button to toggle the function between 'totAL' and 'rAtE'. When set as required press **E** to enter the selection and to return to the configuration menu.

6.8 Lower display: 'di5P-2'

When only one display is required this function allows the lower display to be disabled. To reveal if the lower display is activated select 'di5P-2' from the configuration menu and press **P**. If set as required, press **E** to return to the configuration menu, or press the **▲** or **▼** button to toggle the function between 'on' and 'oFF'. When set as required press **E** to enter the selection and to return to the configuration menu.

6.9 Position of the decimal points: 'dP'

This function defines the position of the decimal point in both the rate and total displays.

Rate display

The rate display can have up to five digits plus sign, the decimal point may be positioned between any of the digits, or may be omitted. The BA358E uses *floating point arithmetic* so moving the position of the rate display decimal point will affect totalisation.

Total display

The total display can have up to eight digits or seven digits with a negative sign, the decimal point may be positioned with up to five digits after it, or it may be omitted.

Notes:

- The position of the decimal point in the Grand Total will be the same as that selected for the Total Display.
- If the total display decimal point can't be moved to the left it is likely that the existing display will be over-ranged by the adjustment. The total display should be reset to zero, which should allow the decimal point to be positioned as required.
- If the decimal point is moved to the right, the existing total display will be truncated, not rounded, the lost precision can not be recovered.

Positioning the decimal points

To adjust the position of either the rate or total display decimal point select 'dP' from the configuration menu and press **P**. The upper display defined as the rate or total display by function 'di5P-1' (section 6.7) will be activated and identified. The decimal point can be positioned by operating the **▼** or **▲** push button, when set as required enter the setting and return to the conditioning menu by operating the **E** button. Alternatively, to position the lower display decimal point press the **P** button which will display and identify the lower display variable, but on the larger upper display. The position of the decimal point can be

positioned in the same way by operating the **▼** and **▲** push buttons, when set as required enter the setting and return to the conditioning menu by operating the **E** button.

6.10 Calibration of the rate display using an external current source: 'CAL'

This function enables the zero and span of the rate display to be adjusted using an external calibrated current source. When used with an accurate traceable current source this is the preferred method of calibration.

Zero	rate display with 4mA input
Span	rate display with 20mA input

To calibrate the rate display select 'CAL' from the configuration menu and press **P**. The BA358E will display 'ZEro' which is a request for a 4mA input current. Adjust the external current calibrator to 4.000mA and again press **P** which will reveal the current zero rate display. The flashing digit of the display can be changed by pressing the **▲** or **▼** buttons, when set as required pressing **P** will transfer control to the next digit. When all the digits have been adjusted, press **E** to enter the new zero and return to the 'ZEro' prompt .

Pressing the **▲** button will cause the BA358E to display 'SPAN' which is a request for a 20mA input current. Adjust the external current calibrator to 20.000mA and again press **P** which will reveal the existing span rate display. The flashing digit of the display can be changed by pressing the **▲** or **▼** buttons, when set as required pressing **P** will transfer control to the next digit. When all the digits have been adjusted press **E** to enter the new rate span and return to the 'SPAN' prompt. Finally press **E** again to return to the configuration menu.

Notes:

- The Rate Totaliser input current must be adjusted to the required value before the zero and span functions are entered by pressing the **P** button.
- Rate Totalisers may be calibrated at currents other than 4 and 20mA, within the range 3.8 to 21.0mA providing the difference between the two currents is greater than 4mA. If these conditions are not complied with, the instrument displays 'Fail' and aborts the calibration.
- If the zero current is greater than the span current the instrument will be reverse acting i.e. an increasing input current will cause the display to decrease.

6.11 Calibration of the rate display using internal reference: '5Et'

Using the '5Et' function the rate display can be calibrated without the need to know the value of the 4/20mA input current, or to disconnect the BA358E Rate Totaliser from the 4/20mA loop.

When using the '5Et' function the instrument's internal reference is used to simulate a 4mA and 20mA input current.

Zero rate display with a simulated 4mA input
Span rate display with a simulated 20mA input

To calibrate the rate display select '5Et' from the configuration menu and press **P**. The Rate Totaliser will display 'ZEro', pressing **P** again will reveal the current rate display at 4mA. The flashing digit can be adjusted by pressing the **▲** or **▼** buttons, when set as required pressing **P** will transfer control to the next digit. When all the digits have been adjusted, press **E** to return to the 'ZEro' prompt.

To adjust the rate display at 20mA, press the **▲** button which will cause the Rate Totaliser to display '5PAN', pressing **P** will then reveal the existing rate display at 20mA. The flashing digit can be adjusted by pressing the **▲** or **▼** buttons, when set as required pressing **P** will transfer control to the next digit. When all the digits have been adjusted press **E** twice to return to the '5PAN' prompt followed and then to the '5Et' prompt in the configuration menu.

6.12 Clear grand total: 'Clr.Gtot'

The grand total is a separate sixteen digit counter which duplicates the total display but is not zeroed when the total display is reset to zero. The grand total may be viewed in the operating mode in two eight digit sections as described in section 2.1 of this manual. The following table illustrates how grand totals are displayed.

Grand total	High display	Low display
1234567890123456	12345678	90123456
-1234		-1234
-12345678	-	12345678
-1234567890	-12	32567890
-123456789012345	-1234567	89012345

The grand total counter can be reset to zero from the 'Clr.Gtot' function in the configuration menu, or from the operating mode if the local grand total reset has been activated, see section 6.17.

To zero the grand total from within the configuration menu select 'Clr.Gtot' and press **P** which will cause the instrument to display 'Clr.no'. Press the **▼** or **▲** button until 'CLr.YES' is displayed and then press **P** which will result in a

'0000' prompt. Using the **▼** and **▲** buttons and the **P** button to move to the next digit, enter '5urE' digit by digit to confirm the instruction. Pressing **E** will then reset the grand total counter to zero, briefly displaying 'Gt CLrd' to confirm that the instruction has been performed and return the instrument to the 'CLr.Gtot' prompt in the configuration menu.

CAUTION

After resetting the original grand total can not be recovered.

6.13 Timebase: t-bA5E

Together with the total scale factor '5CALE-t', this function defines the arithmetic relationship between the rate and total displays. The timebase divides the rate display by 1, 60 or 3,600 depending upon whether the BA358E rate display represents flow per second, per minute or per hour. See Fig 6.

To check or change the timebase select 't-bA5E' from the configuration menu and press **P** which will reveal the current setting. Pressing the **▼** or **▲** button will index through the following three options.

BA358E Rate display Represents flow	Select in t-bA5E menu	Total display = rate display divided by
Per second	'tb - 1'	1
Per minute	'tb - 60'	60
Per hour	'tb - 3600'	3600

After selecting the required divisor, press **E** to return to the 't-bA5E' prompt in the configuration menu.

6.14 Function of the P push-button: 'C - - P'

When the Rate Totaliser is in the operating mode, operating the **P** push button will display the input current in milliamps, or the displayed flow rate as a percentage of the difference between the displayed flow rate at 4mA and 20mA inputs.

To check or change the function of the **P** push button select 'C - -P' from the configuration menu and press **P** to reveal the current setting. Pressing the **▲** or **▼** button will toggle the setting between '4-20' the current display in milliamps and 'PC' the percentage display. When set as required press **E** to return to the 'C - - P' prompt in the configuration menu.

Note: The percentage option 'PC' is not available when the sixteen segment lineariser is selected see section 6.4.

6.15 Total scale factor: '5CALE-t'

Together with the timebase 't-bA5E', this is a dividing factor that defines the arithmetic relationship between the rate and total displays. When the flow rate and the total flow are required in the same units 5CALE-t = 1.0

The total scale factor may be set to any value between 0.0001 and 99999 allowing the total flow and rate of flow to be displayed in different engineering units.

$$5CALE-t = \frac{\text{Units of rate display}}{\text{Units of total display}}$$

When calculating 5CALE-t the required units of measurement for the total display must be converted to those used for the rate display as shown in the following example:

The BA358E rate display represents litres per second but the total flow display is required in UK gallons. There are 4.5461 litres in a UK gallon.

$$\begin{aligned} 5CALE-t &= \frac{\text{Units of rate display}}{\text{Units of total display}} \\ &= \frac{1 \text{ litre}}{1 \text{ gallon}} \\ &= \frac{1 \text{ litre}}{1 / 4.5461 \text{ litres}} \\ 5CALE-t &= 4.5461 \end{aligned}$$

Alternatively, if the total display is required in thousand of UK gallons

$$= \frac{1 \text{ litre}}{1 / 4546.1 \text{ litres}}$$

$$5CALE-t = 4546.1$$

The total scale factor 5CALE-t is not dependent on the rate display units of time. i.e. flow units per second, minute or per hour. The timebase t-bA5E accounts for these differences.

To check or change the total scale factor select '5CALE-t' from the configuration menu and press **P** to reveal the existing setting, one digit will be flashing. The value of the flashing digit may be changed by pressing the **▼** or **▲** button. When this digit is set as required pressing **P** will transfer control to the next digit, which may be adjusted in the same way.

To position the decimal point, repeatedly operate the **P** button until the decimal point starts flashing.

The decimal point can then be positioned by pressing the **▼** or **▲** button.

When the required total scale factor has been set, press **E** to enter the number and return to the '5CALE-t' prompt in the configuration menu.

6.16 Clip-off: 'CLiP-oFF'

To prevent totalisation of very low flow rates, which over long periods may result in significant totalisation errors, the BA358E rate display can be conditioned to stop totalisation when the flow rate falls below a specified clip-off threshold. Clip-off is an absolute value, for bi-direction flow systems it inhibits totalisation for flow rates between +clip-off and -clip-off.

Clip-off is shown in the same units as the instruments rate display. To check or change the clip-off threshold select 'CLiP-oFF' from the configuration menu and press **P** to reveal the current level, one digit will be flashing. The value of the flashing digit may be changed by pressing the **▼** or **▲** button. When this digit is set as required pressing **P** will transfer control to the next digit, which may be adjusted in the same way. When set as required, press the **E** button to enter the revised threshold and return to the 'CLiP-oFF' prompt in the configuration menu.

For uni-directional flow when the flow rate falls below the clip-off threshold, totalisation is inhibited, the hold annunciator is activated but the flow indicator continues to rotate until the input current falls below 4mA.

For bi-directional flow when the positive or negative flow rate is less than the absolute clip-off threshold, totalisation is inhibited and the hold annunciator is activated. The flow indicator continues to rotate until the low rate is less than $\pm 0.05\%$ of flow rate display span.

6.17 Local reset of total and grand total. 'LoC. R5Et'

This function contains two sub-functions 't-rE5Et' and 'Gt-rE5Et' which allow the total display and the grand total to be independently reset using the instrument push buttons without access to the configuration menu from the operating mode.

When enabled, 't-rE5Et' allows an operator to reset the BA358E total display to zero by operating the **▼** and **▲** push buttons simultaneously for at least two seconds. To check the status of 't-rE5Et' select 'LoC.r5Et' from the configuration menu and press **P**. Using the **▼** or **▲** button select 't-rE5Et' and press **P** which will reveal if the function is turned 'on' or 'oFF'. Operating the **▼** or **▲** button will toggle the display between the two conditions.

When set as required pressing the **E** button will enter the selection and return the display to the 't-rE5Et' sub-function. The remote reset facility described in section 4.2 of this manual is not affected by the status of this local reset function.

When enabled, 'Gt-rE5Et' allows an operator to reset the BA358E grand total to zero by operating the **E** and **▲** push buttons simultaneously for at least ten seconds. To check the status of 't-rE5Et' select 'LoC.r5Et' from the configuration menu and press **P**. Using the **▼** or **▲** button select 'Gt-rE5Et' and press **P** which will reveal if the function is turned 'on' or 'oFF'. Operating the **▼** or **▲** button will toggle the display between the two conditions. When set as required pressing the **E** button will enter the selection and return the display to the 'Gt-rE5Et' sub-function.

6.18 Security code: 'CodE'

Access to the instrument configuration menu may be protected by a four digit security code which must be entered to gain access. New instruments are configured with the default security code 0000 which allows unrestricted access to all configuration functions.

To enter a new security code select 'CodE' from the configuration menu and press **P** which will cause the Rate Totaliser to display the existing security code with one digit flashing. The flashing digit can be adjusted using the **▲** and **▼** push buttons, when set as required operating the **P** button will transfer control to the next digit. When all the digits have been adjusted press **E** to return to the 'CodE' prompt in the configuration menu. The revised security code will be activated when the Rate Totaliser is returned to the display mode. Please contact BEKA associates sales department if the security code is lost.

6.19 Reset to factory defaults: 'r5Et'

This function enables the Rate Totaliser and the lineariser to be quickly returned to the factory default configurations shown in sections 6.2 and 7.5

To reset the Rate Totaliser or lineariser select 'r5Et' from the configuration menu and press **P**, the Rate Totaliser will display one of the reset options 'ConF' or 'LtAb'.

'ConF'	Resets the Rate Totaliser to defaults
'LtAb'	Resets the lineariser to defaults

Using the **▲** or **▼** push-button select the required sub-function and press **P**. To prevent accidental resetting the request must be confirmed by entering '5urE'. Using the **▲** button set the first flashing digit to '5' and press **P** to transfer control to the second digit which should be set to 'u'. When '5urE' has been entered pressing the **E** button will reset the selected configuration menus and return the display to the 'r5Et' function in the configuration menu.

6.20 Over-range

Numerical over-range of the rate or total displays is indicated by all the digits displaying '9' and all the decimal points flashing.

When the total display exceeds 99999999 or -99999999 it will not automatically roll-over to zero and continue counting, but the grand total will continue to count. If it is likely that the total will exceed 99999999 or -99999999 the grand total, which has a capacity of 10^{16} and -10^{15} counts, should be reset to zero at the start of the operation.

If the total display exceeds 99999999 or -99999999 when the BA358E has been configured for bi-directional flow, the total display will be locked and will not record flow in the opposite direction to the over-range, although the grand total will continue to function.

7. LINEARISER

A sixteen segment, seventeen breakpoint lineariser may be selected in the 'FunC' section of the configuration menu. The starting point and slope of each straight line segment are fully adjustable allowing the lineariser to be adjusted to compensate for flowmeter nonlinearities.

Each break-point must occur at a current greater than the preceding break-point and less than the following break-point, within the range 3.8 to 21.0mA. Fig 9 shows a typical linearised Rate Totaliser characteristic.

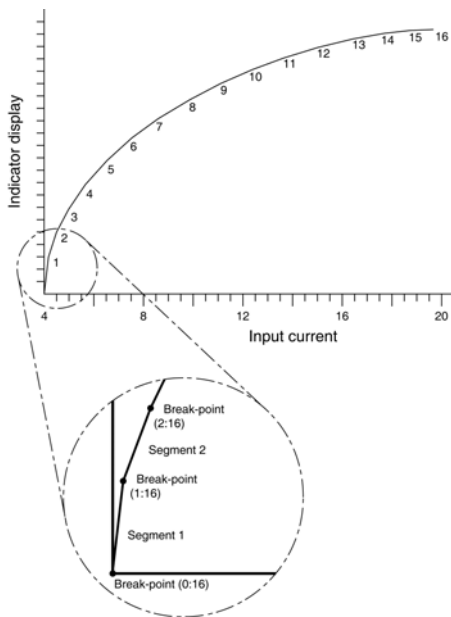

Fig 9 shows a typical linearising characteristic

Selecting 'Lin' or 'bi-Lin' in the 'FunC' section of the configuration menu activates the lineariser, this does not change the configuration menu shown in Fig 8, but the 'CAL' and '5Et' functions are extended as shown in Fig10. As with a linear Rate Totaliser, calibration may be performed with an external current source using the 'CAL' function, or with the internal reference using the '5Et' function.

The lineariser configuration is retained irrespective of how the 'FunC' in the Rate Totaliser configuration menu is subsequently changed. It is therefore possible to select and deselect the lineariser without having to reconfigure it each time.

7.1 Lineariser calibration using an external current source.

This method allows direct calibration of the lineariser with an external current source and is the preferred method when traceability is required.

The number of break-point required should first be entered using the 'Add' and 'dEL' functions. In both of these sub-functions the Rate Totaliser initially displays the current break-point and the total number of break-points being used as shown below.

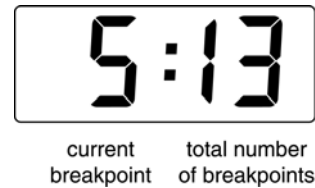

Display

Description of function

'Add'

Add a break-point

Adds a new break-point before the displayed break-point. The calibration of existing break-points is not changed, but the identification number of all subsequent break-points is increased by one.

'dEL'

Remove a break-point

Removes the displayed break-point and joins the preceding break-point to the following break-point with a straight line. The identification number of all subsequent break-points is decreased by one.

To add a break-point use the ▲ or ▼ button to select 'CAL' from the configuration menu and press **P** which will result in the 'Add' sub-function prompt being displayed. To enter the sub-function press **P** which will reveal the current break-point and the total number of break-points which have already been entered. Each subsequent operation of the **P** push-button will introduce an additional break-point up to the maximum of 17 (0:16). When adding a break-point to a calibrated Rate Totaliser, the insertion position for the new segment can be selected using the ▲ and ▼ push-buttons.

The delete break-point sub-function 'dEL' operates in exactly the same way as the 'Add' sub-function described above. Once within the 'dEL' sub-function each time the **P** button is pressed a break-point is removed. When deleting a break-point from a calibrated Rate Totaliser, the break-point to be deleted can be selected using the ▲ and ▼ push-buttons. The minimum number of break-point is 2, break points 0 and 1.

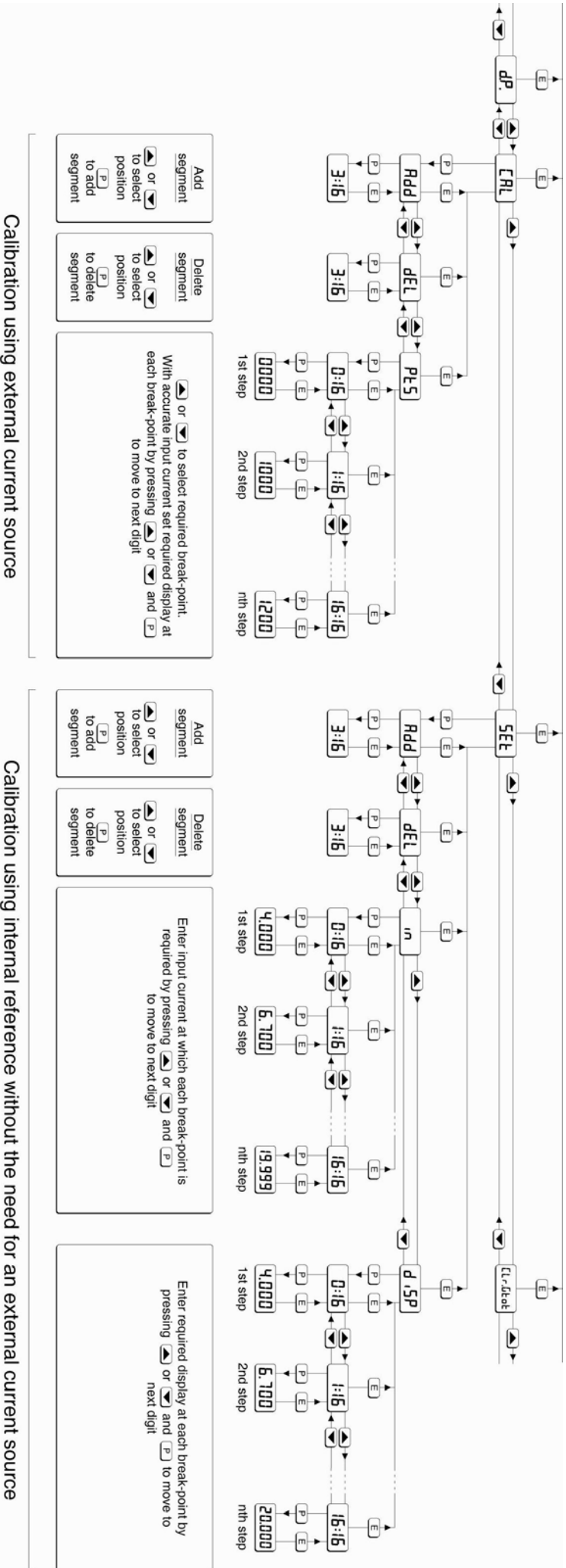

Fig 10 Extension of CAL and SEI functions for lineariser configuration

When the required number of linearising break-points have been entered, return to the linearisation sub-menu by pressing **E**. The Rate Totaliser will display the 'Add' or 'dEL' prompt depending upon the last function used.

Now that the number of break-points has been entered, the input current at which each occurs and the corresponding rate display can be defined by the 'Pts' sub-function.

Using the **▲** or **▼** button select 'Pt5' from the sub-menu and press **P** which will select the starting point for the first segment '0 : n', where n is the total number of linearising break-points entered. The selected linearising break-point can be changed using the **▲** and **▼** buttons. When the required linearising break-point has been selected set the Rate Totaliser input current to the exact value at which the break-point is required and press **P**. Using the **▲** and **▼** buttons and the **P** button to move between digits, enter the required rate display at this break-point.

When set as required, press the **E** push-button to enter the required rate display and return to the sub-menu from which the next break-point can be selected.

When all the break-points have been calibrated pressing **E** twice will return the Rate Totaliser to the 'CAL' function in the configuration menu.

Note: The Rate Totaliser input current must be adjusted to the required value before the **P** button is operated to enter the required rate display.

7.2 Lineariser calibration using the internal reference.

The '5Et' function enables the lineariser to be calibrated without the need for an accurate external current source. Throughout the calibration the Rate Totaliser input current may be any value between 4 and 20mA.

The '5Et' functions contains four sub-functions.

Display	Description of function
'Add'	Add a break-point Adds a new break-point before the displayed break-point. The calibration of existing break-points is not changed, but the identification number of all subsequent break-point is increased by one.

'dEL' **Remove a break-point**
Removes the displayed break-point and joins the preceding segment to the following segment with a straight line. The identification number of all subsequent break-points is decreased by one.

'in' **Defines the current at which break-point occurs.**
Enables the required current at each break-point to be defined without having to input an accurate input current to the Rate Totaliser.

'di5P' **Defines Rate Totaliser display at break-point.**
Enables the rate display at each break-point to be defined.

The number of break-point required should first be entered using the 'Add' and 'dEL' sub-functions. In both these sub-functions the Rate Totaliser initially displays the current break-point and the total number of break-point being used as shown below.

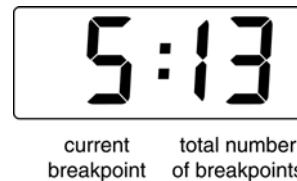

To add a break-point select '5Et' from the configuration menu and press **P** which will result in the 'Add' sub-function prompt being displayed. To enter the sub-function press **P** which will reveal the current break-point and the total number of break-point which have already been entered. Each subsequent operation of the **P** push-button will introduce an additional break-point up to the maximum of 17. When adding a break-point to a calibrated Rate Totaliser, the insertion position for the new segment can be selected using the **▲** and **▼** push-buttons.

The delete break-point, sub-function 'dEL' operates in exactly the same way as the 'Add' sub-function described above. Once within the 'dEL' function each time the **P** button is pressed a break-point is removed. When deleting a break-point from a calibrated Rate Totaliser, the break-point to be deleted can be selected using the **▲** and **▼** push-buttons. The minimum number of break-point is 2, break-points 0 and 1.

When the required number of linearising break-point has been entered, return to the linearisation sub-menu by pressing **E**. The Rate Totaliser will display the 'Add' or 'dEL' prompt depending upon the last sub-function used. The Rate Totaliser input current and corresponding rate display at each break-point, which is the segment finishing point as shown in Fig 9, can now be entered using the 'in' and 'di5P' sub-functions.

Using the ▲ or ▼ button select 'in' from the sub-menu and press **P** which will reveal the starting point for the first segment '0 : n', where n is the total number of break-point entered. Press **P** and use the ▲ and ▼ buttons and the **P** button to move between digits, to enter the input current at which the first break-point is required, usually 4.000mA. When set as required, press **E** to return to the '0 : n' prompt from which the next break-point can be selected using the ▲ and ▼ buttons. When the required break-point has been selected press **P** and enter the Rate Totaliser input current at this break-point. Repeat this procedure until the Rate Totaliser input current at all the break-points has been defined and then return to the 'in' sub-function by pressing the **E** button.

The corresponding rate display at each of the break-points can now be defined using the 'di5P' sub-function. Using the ▲ and ▼ buttons select the 'di5P' sub-function and press **P** which will reveal the starting point for the first break-point '0 : n', where n is the total number of break-points entered. Press **P** and use the ▲ and ▼ buttons and the **P** button to move between digits, to enter the required rate display at the first break-point. When set as required, press **E** to enter the setting and return to the '0 : n' prompt from which the next break-point can be selected using the ▲ or ▼ buttons. When the required break-point has been selected press **P** and set the required rate display at this break-point.

Repeat this procedure until the rate displays at all the break-points have been entered and then return to the '5Et' function in the configuration menu by pressing the **E** button twice.

7.3 Lineariser error message

If an attempt is made to position a break-point at a current which is not greater than the current of the preceding break-point, or at a current which is not less than the current of the following break-point, the error message 'Fail' will be displayed. This error message will also be displayed if an attempt is made to position a break-point outside the current range 3.8 to 21.0mA.

7.4 Under and over-range

The lineariser does not change the under and over-range indication described in section 6.20. At input currents below that specified for the first break-point (0), the Rate Totaliser will continue to use the specified slope of the first segment.

At input currents above that specified for the last break-point, the Rate Totaliser will continue to use the slope specified for the last lineariser segment.

7.5 Lineariser default configuration

When the lineariser is reset to the default conditions using the 'r5Et' reset function described in section 6.19, the defaults conditions are:

	Rate display
First break-point 4mA	0.00
Second break-point 20mA	100.00

8. CALIBRATION EXAMPLES

This section contains two examples illustrating how a BA358E Rate Totaliser may be configured and calibrated to display the rate of flow and total flow measured by a flow meter with a 4/20mA output. Section 8.1 describes the preferred method of calibration using an external traceable 4/20mA calibrator. Section 8.2 contains an example of calibration using the BA358E internal 4 and 20mA references, which although not traceable, are adequate for many industrial applications.

8.1 Using an external current source

In this example the BA358E Rate Totaliser is connected to a flowmeter having a linear output of 20mA at a flow of 1100 litres / minute. The BA358E is required to display flow in litres per minute with a resolution of 1 litre and total flow in cubic metres with a resolution of 0.1 cubic metres. Total is to be shown on the upper large display and rate on the lower smaller display. Totalisation is to occur for flow rates between 1 and 100% of maximum flow. A security code of 1209 is required. In the operating mode the BA358E is required to display the input current as a percentage of span when the **P** push button is operated. Local resetting of the total display to zero is required.

Step 1 Connect instrument to calibrator

Connect the BA358E to an accurate current source such as a calibrator. Terminal 1 positive and terminal 3 negative. The instrument will perform the initialisation routine described in section 2.

Step 2 Enter the configuration menu

With an input current between 4 and 20mA put the instrument enter the configuration menu by simultaneously pressing **P** and **E**. Assuming a security code has not already been entered the instrument will respond by displaying 'FunC' which is the first function in the configuration menu.

Step 3 Select Rate Totaliser function

The flowmeter has a linear 4/20mA output so neither the root extractor or the lineariser are required. The standard linear relationship should therefore be selected. With 'FunC' displayed, press **P** which will reveal the existing function. Using the **▼** or **▲** button select 'Std'. Press **E** to enter this selection and return to the 'FunC' prompt in the configuration menu.

Step 4 Define function of **P** push button

Select 'C--P' from the configuration menu and press **P** to reveal the function of the **P** button in the operating mode. Select percentage 'PC' and return to the configuration menu by pressing **E**.

Step 5 Define rate display resolution

Maximum rate display resolution is required. Select 'rE5n' from the main menu and press **P** to reveal the current resolution of the rate display. Using the **▼** and **▲** push buttons select a resolution of '1' and return to the 'rE5n' prompt in the configuration menu by pressing **E**.

Step 6 Rate and total display location.

The upper display is required to show the total flow. Select 'di5P-1' from the configuration menu and press **P** to reveal the current upper display variable. Using the **▼** and **▲** push buttons select 'totAL' and return to the 'di5P-1' prompt in the configuration menu by pressing **E**.

The lower display is required to show the flow rate. Select 'di5P-2' from the configuration menu and press **P** to reveal if this display is activated. Using the **▼** and **▲** push buttons select 'on' and return to the 'di5P-2' prompt in the configuration menu by pressing **E**.

Step 7 Position rate & total decimal points

Select 'dP' from the configuration menu and press **P**. The upper display will be activated and will show the total display. Press the **▲** or **▼** push button to position the decimal point in front of the least significant digit of the display. This gives the required total display resolution of 0.1

Press **P** to change the upper display from total to rate. Using the **▲** or **▼** push button move the decimal point to the right hand side of the least significant digit where it is not displayed. This gives the required rate display resolution of 1 litre with no decimal point visible.

Finally press **E** to return to the 'dP' prompt in the main menu.

Step 8 Calibrate the rate display

Select calibration of the rate display using an external current source 'CAL' from the configuration menu and press **P**. The BA358E will request a 4mA input by displaying 'ZEro'. Set the input current to 4.0000mA and press **P** which will reveal the existing rate display with one digit flashing. Using the **▼** and **▲** buttons to adjust each digit and the **P** push button to move control between digits, enter the required zero display of 0000. Press **E** to enter this calibration figure and return the instrument to the 'ZEro' prompt.

Press the **▲** push button and the instrument will request a 20mA input by displaying 'SPAN'. Set the input current to 20.0000mA and press **P** which will reveal the existing rate display at 20mA. Using the **▼**, **▲** and **P** push buttons enter the required display of 1100.0

Press **E** to enter this calibration figure and return the instrument to the 'SPAN' prompt and again to return to the 'CAL' prompt in the configuration menu.

Step 9 Define the timebase

In this example the rate display represents flow per minute so it is necessary to set the instrument timebase to 60. This will divide the rate display by 60 to provide the correct total display.

Select 't-bA5E' from the main menu and press **P** to reveal the current setting. Using the **▼** and **▲** push buttons select 'tb - 60' and then return to the configuration menu by pressing **E**.

Step 10 Define the totaliser scaling factor

In this example the rate display is in litres per minute but the total display is required in cubic metres:

$$5\text{SCALE-t} = \frac{\text{Units of rate display}}{\text{Units of total display}}$$

There are 1,000 litres in a cubic metre thus:

$$= \frac{\text{litres}}{\text{cubic metres}}$$

$$= \frac{1 \text{ litre}}{1/(1000) \text{ litres}}$$

$$5\text{SCALE-t} = 1000$$

From the configuration menu select '5SCALE-t' and press **P** to reveal the current five digit dividing factor. Using the **▼** and **▲** buttons to adjust the flashing digit, and the **P** button to transfer control between digits.

The position of the decimal point is adjusted by repeatedly pressing the **P** button until the decimal point flashes. The decimal point can then be moved to the required position by operating the **▼** or **▲** button. When set to 1000.0 press **E** to return to the '5SCALE-t' prompt in the configuration menu.

Step 11 Define totalisation clip-off

In this example totalisation is to be inhibited below 1% (11 litres / minute) of maximum flow. To define this cut-off point select 'CLiP-oFF' from the configuration menu and press **P** which will reveal the existing setting. Using the **▼**, **▲** and **P** push buttons enter the required clip-off of 11.0 and then return to the 'CLiP-oFF' prompt in the configuration menu by pressing **E**.

Step 12 Local reset of total display

This example requires that the total display resets to zero when the **▼** and **▲** buttons are operated simultaneously. To enable this function select 'LoC.r5Et' from the configuration menu and press **P** which will reveal if the function is on or off. Using the **▼** or **▲** button toggle the display to 'on' and return to the configuration menu by pressing **E**.

Step 13 Reset the grand total to zero

To reset the grand total to zero select 'CLr.Gtot' from the configuration menu and press **P** which will cause the instrument to display 'Clr.no'. Toggle this to 'CLr.YES' using the ▼ or ▲ push button and press **P** which will result in a '0000' prompt. Using the ▼, and ▲ buttons and the **P** button to move control to the next digit, confirm the request by entering the password 'SurE'. Note: S is entered as 5. Pressing **E** will then reset the grand total counter to zero and return the instrument to the 'CLr.Gtot' prompt in the configuration menu.

Step 14 Enter security code

The example requires that access to the Rate Totaliser configuration menu is protected by the security code 1209. To enter this code select 'CodE' from the configuration menu and press **P** which will reveal the existing security code with one flashing digit. Using the ▼ and ▲ push buttons and the **P** button to transfer control between digits set the code to 1209 and then press **E** to enter the code and return to 'CodE' prompt in the configuration menu.

Step 15 Return to the Rate Totaliser operating mode.

Configuration is now complete, return to the Rate Totaliser operating mode by pressing the **E** button.

8.2 Using the internal reference

This example explains how to calibrate a BA358E Rate Totaliser using the instruments internal reference which means that it does not have to be disconnected from the measuring loop and no test equipment is required.

As in the previous example the BA358E Rate Totaliser is connected to a flowmeter having a linear output of 20mA at a flow of 1100 litres / minute. The BA358E is required to display flow in litres per minute with maximum resolution and total flow in cubic metres with a resolution of 0.1 cubic metres. Total is to be shown on the upper large display and rate on the lower smaller display. Totalisation is to occur for flow rates between 1 and 100% of maximum flow. A security code of 1209 is required. In the operating mode the BA358E is required to display the input current as a percentage of span when the **P** push-button is operated and operating the ▼ and ▲ buttons simultaneously to reset the total display to zero.

All the configuration steps are identical to those in the previous example except for steps 1 and 8.

Step 1 Leave the BA358E in measurement loop.

It is not necessary to remove the BA358E Rate Totaliser from the measurement loop to reconfigure it using the instruments internal references. Throughout the procedure the loop current must be between 4 and 20mA.

Step 8 Calibrate the rate display

Select calibration of the rate display using the internal reference '5Et' from the configuration menu and press **P**. The BA358E will display 'Zero', pressing **P** again will reveal the calibrated rate display at 4mA input with one digit flashing. The ▼ and ▲ push buttons will adjust the flashing digit and the **P** push button will transfer control to the next digit. Enter 0000.0 and then press **E** to return to the 'ZEro' prompt.

Press the ▲ button to access the 'SPAn' prompt and press **P** which will reveal the calibrated rate display at 20mA with one digit flashing. The ▼ and ▲ push buttons will adjust the flashing digit and the **P** push button will transfer control to the next digit. Enter 1100.0 and then press **E** to return to the 'SPAn' prompt. Finally, press **E** again to enter the new rate calibration and return to the '5et' prompt in the configuration menu.

Step 9 Return to the Rate Totaliser operating mode.

Configuration is now complete, return to the Rate Totaliser operating mode by pressing the **E** button.

9. MAINTENANCE

9.1 Fault finding during commissioning

If a BA358E fails to function during commissioning the following procedure should be followed:

Symptom	Cause	Check
No display	Incorrect wiring	Check wiring There should be 0.6 to 1.2V between terminals 1 & 3 with terminal 1 positive. With an optional backlight, loop powered, there should be 3.4 to 5V between terminals 3 & 12 with terminal 12 positive.
No display 0V between terminals 1 & 3.	Incorrect wiring or no power supply	Check supply voltage and voltage drop caused by all the instruments in the loop.
Rate display showing -99999 or 99999 with all decimal points flashing	Over-range	The rate display has been incorrectly calibrated & is trying to display a number outside the range -99999 to 99999. Recalibrate rate display.
Total display showing -9999999 or 99999999 with all decimal points flashing	Over-range	Reset total display to zero.
Unstable rate display	4/20mA current has a large ripple content	Eliminate source of electrical noise . Reduce resolution of the rate display to mask flow noise
Unable to access configuration menu	Incorrect security code	Enter the correct security code

9.2 Fault finding after commissioning

ENSURE PLANT SAFETY BEFORE STARTING MAINTENANCE

Live maintenance is permitted on intrinsically safe equipment installed in a hazardous area, but only certified test equipment should be used unless a gas clearance certificate is available.

If a BA358E fails after it has been functioning correctly, the following table may help to identify the cause of the failure.

Symptom	Cause	Check
No display and no voltage between terminals 1 & 3	No power supply.	Confirm that a 4/20mA current is flowing in the loop.
Unstable rate display	4/20mA current is noisy or the flow signal is unstable	Eliminate source of electrical noise . Reduce resolution of the rate display to mask flow noise
Unable to access configuration menu	Incorrect security code	Enter the correct security code
Rate display showing 99999 with all decimal points flashing	Over-range	The rate display has been incorrectly calibrated & is trying to display a number greater than 99999.
Total display showing 99999999 with all decimal points flashing	Over-range	The total display has been incorrectly calibrated & is trying to display a number greater than 99999999.

If this procedure does not reveal the cause of the fault, it is recommended that the instrument is replaced.

9.3 Servicing

All BA358E loop powered Rate Totalisers are interchangeable if the required optional backlight and alarms are fitted. A single spare instrument may quickly be recalibrated to replace any instrument that is damaged or fails. No attempt should be made to repair instruments at component level.

We recommend that faulty instruments are returned to BEKA associates or to your local BEKA agent for repair.

9.4 Routine maintenance

Routine maintenance should comply with the recommendations contained in BS EN 6007-17 'Electrical Installations Inspections and Maintenance'. The mechanical condition of the instrument and electrical calibration should be regularly checked. The interval between inspections depends upon environmental conditions. We recommend that initially instrument calibration should be checked annually.

9.5 Guarantee

Instruments which fail within the guarantee period should be returned to BEKA associates or our local agent. It is helpful if a brief description of the fault symptoms is provided.

9.6 Customer comments

BEKA associates is always pleased to receive comments from customers about our products. All communications are acknowledged and whenever possible, suggestions are implemented.

10. ACCESSORIES

10.1 Scale card

The BA358E Rate Totaliser has a window on the right hand side of the display through which a scale card showing the units of measurement such as m/sec, Galls., m³/hour can be viewed. New instruments are fitted with a scale card showing the units of measurement specified when the Rate Totaliser was ordered, if the units are not specified a blank scale card will be fitted. A pack of scale cards pre-printed with common flow units of measurement is available as an accessory. These can easily be fitted on-site to the BA358E without opening the instrument enclosure or removing it from the panel, see section 5.4 of this instruction manual.

Custom scale cards for applications requiring less common units of measurement are also available.

10.2 Tag information

New Rate Totalisers are supplied with the tag or application information specified when ordered thermally printed onto the rear panel adjacent to the terminals. This tag information is not visible from the front of the instrument after installation.

10.3 Alarms

CAUTION

These alarms outputs should not be used for critical safety applications such as an emergency shut down system.

The BA358E Rate Totaliser can be supplied with factory fitted dual alarms with solid state, single pole outputs. Each output may be independently configured as a rate or total, high or low alarm with a normally open or normally closed output in the non-alarm condition.

When the 4/20mA current powering the Rate Totaliser is removed both alarm outputs will open irrespective of configuration. The open circuit condition should therefore be chosen as the alarm condition when designing an alarm system. Fig 11 illustrates the conditions available and shows which are fail safe.

When an alarm occurs an alarm annunciator on the Rate Totaliser display is activated and if required the rate or total display causing the alarm can alternate between the measured value and the alarm channel identification 'ALr1', 'ALr2' or 'ALr1-2' if both alarms are activated by the same variable..

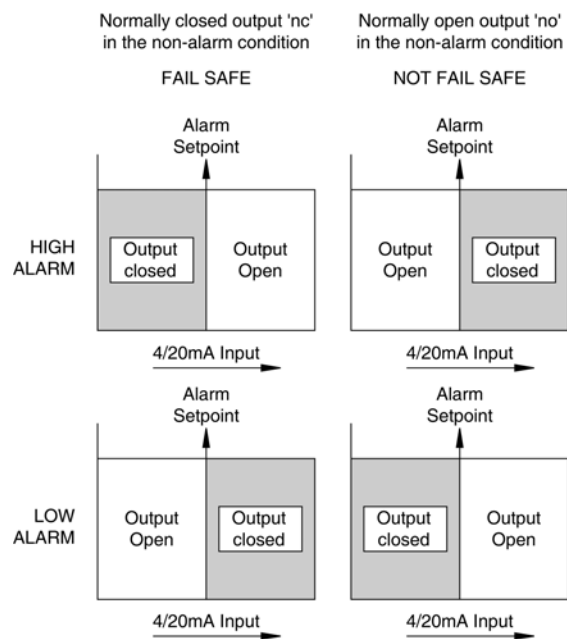

Fig 11 Alarm outputs

Configurable functions for each alarm include activation from rate display or total display, adjustable setpoint, hysteresis, alarm delay and alarm silence time.

10.3.1 Solid state output

Each alarm has a galvanically isolated single pole solid state switch output as shown in Fig 12. The output is polarised and current will only flow in one direction.

$$\begin{aligned} R_{on} &= \text{less than } 5\Omega + 0.7V \\ R_{off} &= \text{greater than } 1M\Omega \end{aligned}$$

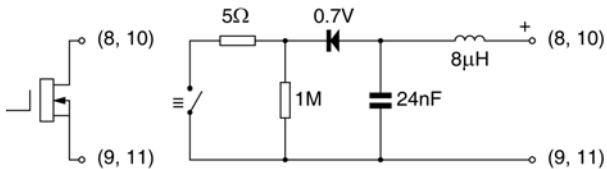

Fig 12 Equivalent circuit of each alarm output

10.3.2 Intrinsic safety

Each alarm output is a separate galvanically isolated intrinsically safe circuit. The EC-Type Examination Certificate states that for intrinsic safety considerations, under fault conditions the output voltage, current and power at terminals 8 & 9 and 10 & 11 will not exceed those specified by clause 5.7 of EN 60079-11 for *simple apparatus*. This simplifies system documentation and allows the alarm output terminals 8 & 9 and 10 & 11 to be connected to almost any intrinsically safe circuit protected by a Zener barrier or galvanic isolator providing the output parameters of the circuit do not exceed:

$$\begin{aligned} U_o &= 30V \text{ dc} \\ I_o &= 200mA \\ P_o &= 0.84W \end{aligned}$$

The maximum equivalent capacitance and inductance between each set of alarm terminals is:

$$\begin{aligned} C_i &= 24nF \\ L_i &= 8\mu H \end{aligned}$$

To determine the maximum permissible cable parameters these figures should be subtracted from the maximum permitted cable capacitance and inductance specified by the certificate for the interface powering the alarm circuit, such as the solenoid driver and switch transfer galvanic isolators shown in Fig 13.

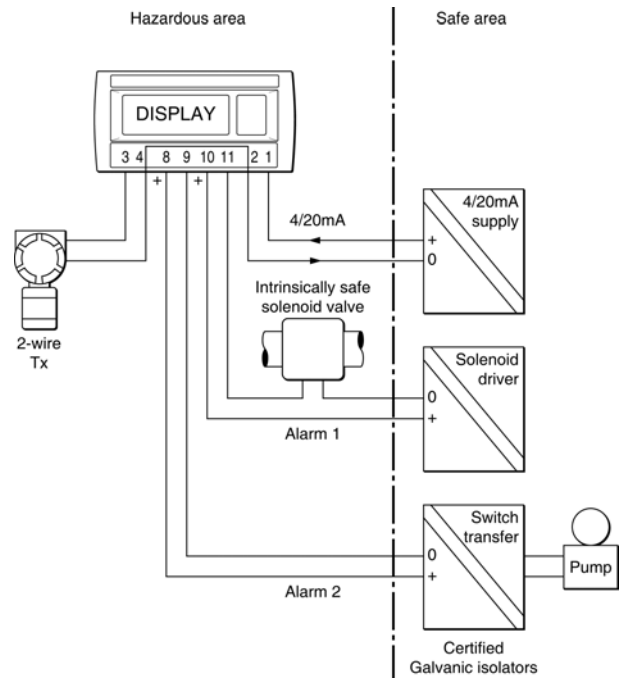

Fig 13 Typical alarm application
(Shown without recommended screened cables)

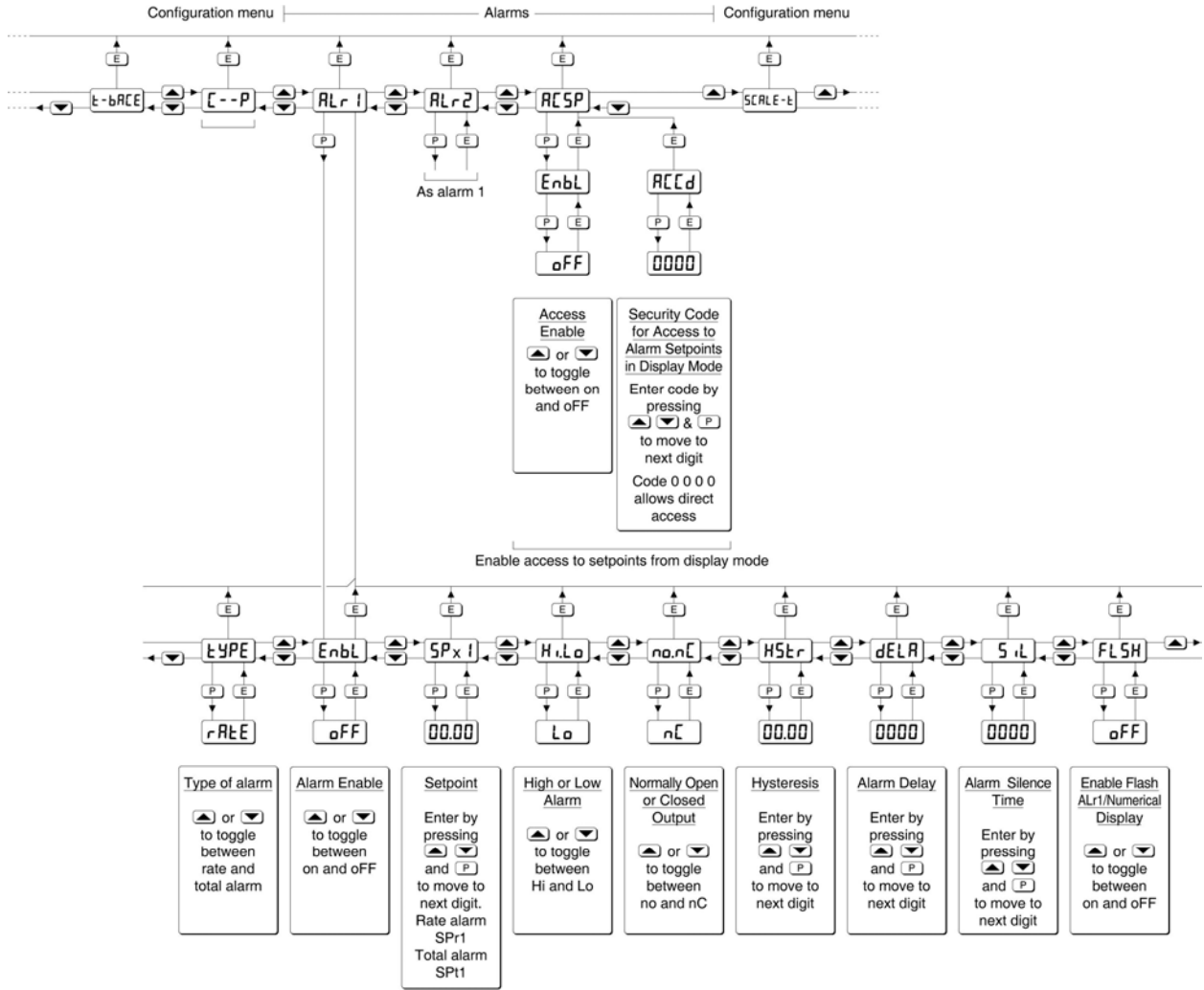

Fig 14 Alarm Configuration Functions in Configuration Menu

10.3.3 Configuration and adjustment

When optional alarms are fitted to a BA358E Rate Totaliser the configuration menu is extended as shown in Fig 13. The additional functions appear between the 'C- - P' and '5CALE-t' functions. For simplicity, Fig 14 only shows the additional functions for alarm 1, but alarm 2 has identical functions.

The following table summaries each of the alarm configuration functions and includes a cross reference to more detailed information. Again only the functions on Alarm 1 are listed, but alarm 2 has identical facilities.

Summary of alarm configuration functions

Display	Description of function
'EnbL'	Alarm enable Enables or disables the alarm without changing the alarm parameters. See section 10.3.4
'tYPE'	Type of alarm Defines whether the alarm operates on the rate or total display. See section 10.3.5
'5Pr1' or '5Pt1'	Alarm setpoint 1 Adjusts the alarm setpoint. The alarm is activated when the selected display (rate or total) equals the setpoint. See section 10.3.6
'Hi.Lo'	Alarm function Defines the alarm function as High or Low. See section 10.3.7
'no.nC'	Normally open or normally closed output. Sets the alarm output open or closed in the non-alarm condition. See section 10.3.8
'H5tr'	Hysteresis Adjusts the alarm hysteresis. Only available on rate alarms. See section 10.3.9
'dELA'	Alarm delay time Introduces adjustable delay between the display equalling the setpoint and the alarm output being activated. See section 10.3.10
'5iL'	Alarm silence time Defines the time that the alarm output remains in the non-alarm condition following acceptance of an alarm. See section 10.3.11
'FL5H'	Flash display when alarm occurs When enabled and an alarm occurs, alternates the rate or total display, depending upon which has caused the alarm, between the process value and the alarm reference 'ALr1' or 'ALr2'. See section 10.3.12
'AC5P'	Access setpoint Sub-menu which enables direct access to the alarm setpoints from the Rate Totaliser display mode and defines a separate security code. See section 10.3.13

10.3.4 Alarm enable: 'EnbL'

This function allows each alarm to be enabled or disabled without altering any of the alarm parameters. To enable or disable the alarm select 'EnbL' from the alarm menu and press **P** which will reveal the current setting 'on' or 'oFF'. The function can be changed by pressing the **▲** or **▼** button followed by the **E** button to return to the alarm menu.

10.3.5 Type of alarm: tYPE

This function conditions the alarm to operate on the rate or total display. Alarm 1 and Alarm 2 may both be rate or total alarms, or one may be conditioned for rate and the other for total.

To check or change the type of alarm, select 'tYPE' from the alarm menu and press **P** which will reveal the current setting. The function can be changed by pressing the **▲** or **▼** button followed by the **E** button to return to the alarm menu.

Note: When the 'tYPE' function is changed all associated alarm functions are reset to default conditions.

10.3.6 Setpoint adjustment: '5Px1' and '5Px2'

The setpoint of each alarm may be positioned anywhere in the numerical display of the selected rate or total display.

The setpoint identification changes depending on the type of alarm. If the alarm has been conditioned by the 'tYPE' function to operate on the rate display the setpoint will be identified as '5Pr1', if operating on the total display it will be identified 5Pt1.

To adjust the setpoint select '5Px1' or '5Px2' from the alarm configuration menu and press **P** which will reveal the existing alarm setpoint. The flashing digit of the setpoint can be adjusted using the **▲** and **▼** push buttons, and the **P** button to move control to the next digit. When the required setpoint has been entered press **E** to return to the alarm configuration menu.

The alarm setpoints may also be adjusted when the Rate Totaliser is in the display mode, see section 9.3.13.

10.3.7 Alarm function: 'Hi.Lo'

Each alarm can be independently conditioned as a high alarm or as a low alarm. To check or change the alarm function select 'Hi.Lo' from the alarm menu and press **P** to reveal the current setting. The function can be changed by pressing the **▲** or **▼** button followed by the **E** button to return to the alarm menu.

10.3.8 Alarm output status: 'no.nC'

Configures the solid state alarm output to be open 'no' or to be closed 'nC' in the non-alarm condition. When deciding which is required, care should be taken to ensure that the alarm output is fail safe as illustrated in Fig 11.

'no' Alarm output open in non-alarm condition

'nC' Alarm output closed in non-alarm condition

CAUTION

When the 4/20mA supply is removed from the loop powered Rate Totaliser, both alarm outputs will open irrespective of configuration. Therefore for fail safe operation both alarm outputs should be configured to be open in the alarm condition 'nC'.

To check or change the alarm output status, select 'no.nC' from the alarm configuration menu and press **P** to reveal the setting. The function may be changed by pressing the **▲** or **▼** button followed by the **E** button to return to the alarm configuration menu.

10.3.9 Hysteresis: H5tr

Only functions on rate display

Hysteresis is shown in the units that the rate display has been calibrated to display.

To adjust the hysteresis select 'H5tr' from the alarm menu and press **P** which will reveal the existing figure. The flashing digit can be adjusted using the **▲** and **▼** push buttons, and the **P** button will move control to the next digit. When the required hysteresis has been entered press **E** to return to the alarm configuration menu.

e.g. A BA358E calibrated to display a rate of 0 to 10000, with a high alarm set at 9000 and hysteresis of 200 will perform as follows:

The high alarm will be activated when increasing rate display equals 9000, but will not reset until the rate display falls below 8800.

10.3.10 Alarm delay: dELA

This function delays activation of the alarm output for an adjustable time following the alarm condition occurring. The delay can be set in 1 second increments between 0 and 3600 seconds. If a delay is not required zero should be entered. To adjust the delay select 'dELA' from the alarm configuration menu and press **P** which will reveal the existing delay. The flashing digit of the delay can be adjusted using the **▲** and **▼** push buttons, and the **P** button to move control to the other digits. When the required delay has been entered press **E** to return to the alarm menu.

e.g. A Rate Totaliser with a high alarm set at 9000 and an alarm delay of 30 seconds will perform as follows:

The alarm annunciator will start to flash when an increasing rate display equals 9000, but the alarm output will not be activated until the alarm condition has existed continuously for 30 seconds. When the alarm output is activated, the alarm annunciator will stop flashing and become permanently activated.

If the 'FL5H' function, which flashes the Rate Totaliser display when an alarm occurs, has been enabled, it will not start to function until the alarm output is activated.
See section 9.3.12

10.3.11 Alarm silence time: SiL

This function is primarily intended for use in small installations where the alarm output directly operates an alarm annunciator such as a sounder or beacon. When the alarm silence time, which is adjustable between 0 and 3600 seconds in 1 second increments, is set to any figure other than zero, the **P** push-button becomes an alarm accept button. After an alarm has occurred, operating the **P** button will cause the alarm output to revert to the non-alarm condition for the programmed alarm silence time. If the alarm condition still exists at the end of the silence time, the alarm output will be reactivated. During the silence time the Rate Totaliser alarm annunciator will flash until the silence time expires or the alarm is cleared.

If the 'FL5H' function, which flashes the Rate Totaliser display when an alarm occurs has been enabled, it will only function when the alarm output is activated, not during the silence time.
See section 9.3.12

To adjust the alarm silence time select '5iL' from the alarm configuration menu and press **P** which will reveal the existing silence time. The flashing digit of the silence time can be adjusted using the **▲** and **▼** push-buttons, and the **P** button to move control to the other digits. When the required silence time has been entered press **E** to return to the alarm menu.

10.3.12 Flash display when alarm occurs 'FL5H'

In addition to the two alarm annunciators on the Rate Totaliser display which show the status of both alarms, this function provides an even more conspicuous indication that an alarm condition has occurred.

When enabled, the rate or total display depending upon which has caused the alarm, alternates between the numerical value and the alarm

reference, 'ALr1' or 'ALr2' when the alarm output is activated. If both alarm outputs are activated by one variable, the display alternates between the numerical value and 'ALr1-2'.

To enable or disable the function select 'FL5H' from the alarm menu and press **P** which will reveal the current setting. The function can be changed by pressing the **▲** or **▼** button followed by the **E** button to return to the alarm menu.

10.3.13 Access setpoint in display mode: AC5P

This function enables a separate menu providing access to the alarm setpoints from the display mode by simultaneously operating the **P** and **▲** push buttons. An operator can therefore adjust the alarm setpoints without having access to the Rate Totaliser configuration menu. Protection against accidental adjustment of the setpoints when the Rate Totaliser is in the display mode is provided by a separate security code.

This direct setpoint access menu is enabled and the separate security code entered from the 'AC5P' function in the alarm configuration menu as shown in Fig 14. To change the menu parameters select 'AC5P' from the configuration menu and press **P** which will display the enable prompt 'EnbL'. Press **P** again to reveal if the direct access menu is 'on' or 'oFF'. The **▲** or **▼** button will toggle the display between the two conditions.

If 'oFF' is selected, the operator will not have access to the setpoints from the display mode. Return to the 'AC5P' prompt in the main menu by pressing **E** twice.

If 'on' is selected, the operator will have direct access to the alarm setpoints from the display mode via a separate optional security code. To define this four digit security code press **P** to return to the 'Enbl' prompt followed by the **▲** or **▼** button to select the access code prompt 'ACCd'. Pressing **P** will reveal the current security code. Each digit of the code may be changed by operating the **▲** and **▼** push buttons, and the **P** button to move control to the next digit. When the required code has been entered, press **E** twice to return to the 'AC5P' prompt in the configuration menu.

Default code 0000 will disable the security code allowing direct access to the setpoints in the display mode by pressing the **P** and **▲** buttons simultaneously. Unless otherwise requested new instruments with alarms are supplied with this function disabled and the security code set to 0000.

10.3.14 Adjusting alarm setpoints from the display mode.

Access to the alarm setpoints from the Rate Totaliser display mode is obtained by operating the **P** and **▲** push buttons simultaneously as shown in Fig 15. If the setpoints are not protected by a security code the alarm setpoint prompt '5Px1' will be displayed. If the setpoints are protected by a security code, 'Code' will be displayed first. Pressing **P** again will enable the alarm security code to be entered digit by digit using the **▲** and **▼** buttons to change the flashing digit, and the **P** push-button to move control to the next digit. If the correct code is entered pressing **E** will cause alarm setpoint prompt '5Px1' to be displayed. Pressing the **▲** or **▼** button will toggle the display between the two alarm setpoint prompts '5Px1' and '5Px2'.

If an incorrect security code is entered, or a button is not pressed within twenty seconds, the Rate Totaliser will automatically return to the display mode.

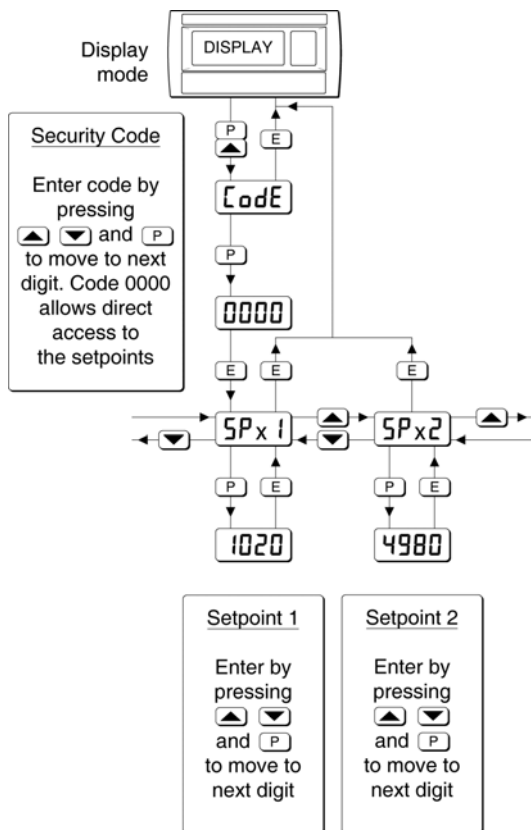

Fig 15 Setpoint adjustment from the display mode

To adjust an alarm setpoint select '5Px1' or '5Px2' and press **P** which will reveal the current setting. Each digit of the setpoint may be adjusted using the **▲** and **▼** push-buttons, and the **P** button to move control to the next digit. When the required setpoint has been entered, pressing **E** will return the display to the '5Px1' or '5Px2' prompt from

which the other setpoint may be selected, or the Rate Totaliser may be returned to the display mode by pressing **E** again.

Notes:

1. With the Rate Totaliser in the display mode, direct access to the alarm setpoints is only available when the AC5P menu is enabled - see section 10.3.13.
2. While the alarm setpoints are being adjusted from the display mode totalisation is suspended, any flow occurring during this time will not be recorded.
3. The setpoint identification changes depending on the type of alarm. If alarm 1 has been conditioned by the 'TYPE' function to operate on the rate display the setpoint will be identified as '5Pr1', if operating on the total display it will be identified 5PT1. Similarly for alarm 2.

10.4 Display backlight

The BA358E loop powered Rate Totaliser can be supplied with a factory fitted backlight that may be loop or separately powered.

When loop powered the backlight produces green background illumination enabling the display to be read at night or in poor lighting conditions. No additional power supply, intrinsic safety interface or field wiring are required, but the Rate Totaliser voltage drop is increased. When separately powered the backlight is brighter, but an additional intrinsic safety interface and field wiring are required.

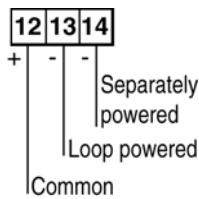

Fig 16 Terminals for optional backlight

10.4.1 Loop powering the backlight

The backlight is loop powered by connecting it in series with the Rate Totaliser's 4/20mA input as shown in Fig 17, which increases the maximum Rate Totaliser voltage drop from 1.2 to 5V.

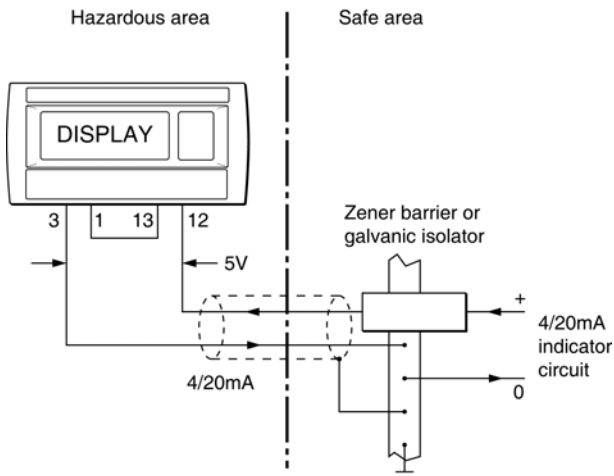

Fig 17 Loop powered backlight

The input intrinsic safety parameters of the combined Rate Totaliser and backlight are the same as for the Rate Totaliser alone. The EC-Type Examination Certificate states that for intrinsic safety considerations, under fault conditions the output voltage, current and power of the combined Rate Totaliser and backlight terminals 12 & 3 will not exceed those specified by clause 5.7 of EN 60079-11 for *simple apparatus*, which simplifies system design and documentation. Providing the increased voltage drop can be tolerated the intrinsic safety and system design

described in sections 3 and 4 of this manual remain valid with the backlight loop powered.

10.4.2 Separately powering the backlight

The optional backlight may also be powered from a separate safe area power supply via an intrinsically safe interface as shown in Fig 18.

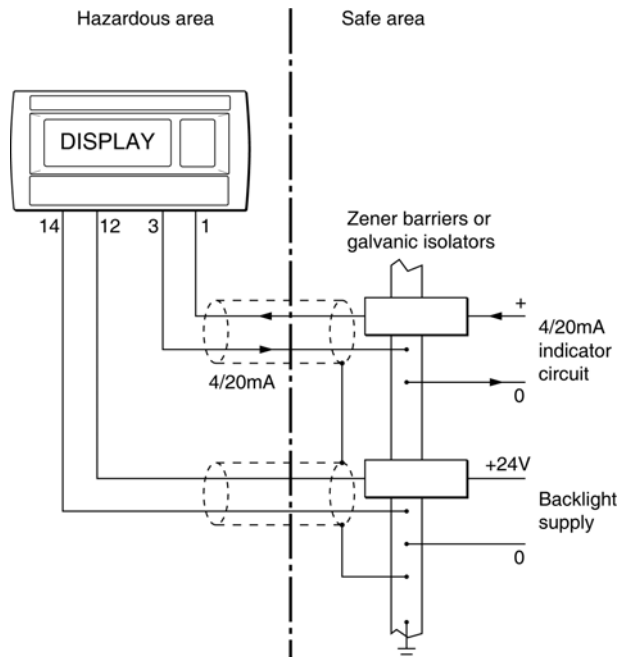

Fig 18 Separately powered backlight

When separately powered the backlight is a current sink drawing a constant current when the supply is equal to or greater the minimum specified voltage. Below this supply voltage the backlight continues to function but with reduced brilliance.

Current	Minimum voltage
35mA	11V

Any certified Zener barrier or galvanic isolator may be used, providing the output parameters do not exceed:

U_o	=	30V dc
I_o	=	200mA
P_o	=	0.84W

The following equivalent internal capacitance and inductance between terminals 12 & 14 should be subtracted from C_o and L_o of the intrinsically safe interface powering the backlight to provide the maximum permissible cable parameters.

C_i	=	13nF
L_i	=	8μH

Appendix 1 ATEX Dust Certification

In addition to ATEX certification permitting installation in explosive gas atmospheres which is described in the main section of this instruction manual, all BA358E Rate Totalisers have ATEX certification permitting installation in combustible dust atmospheres.

This appendix describes ATEX installations in explosive dust atmospheres conforming with EN 60079-14 Electrical installations design, selection and erection. When designing systems for installation outside the UK the local Code of Practice should be consulted.

The Rate Totaliser's dust input and output safety parameters are identical to the gas safety parameters, so all the electrical circuits shown in the main section of this manual may also be used for dust applications.

A1.1 Zones, and Maximum Surface Temperature

The BA358E has been ATEX certified as Group II, Category 1D Ex ia IIIC T80°C Da IP20 apparatus, Ta -40 to 70°C.

When connected to a suitable system the Rate Totaliser may be installed in:

- Zone 20 explosive atmosphere in the form of a cloud of combustible dust in air is continuously present, or for long periods or frequently.
- Zone 21 explosive atmosphere in the form of a cloud of combustible dust in air is likely to occur occasionally in normal operation.
- Zone 22 explosive atmosphere in the form of a cloud of combustible dust in air is not likely to occur in normal operation, but if it does occur, will only persist for a short period.

Be used with dust in subdivisions:

- IIIA combustible flyings
- IIIB non-conductive dust
- IIIC conductive dust
(For use with IIIC conductive dusts special conditions for safe use apply – see section A1.4)

Having a Minimum Ignition Temperature of:

Dust cloud	120°C
Dust layer on Rate Totaliser up to 5mm thick	155°C
Dust layer on Rate Totaliser over 5mm thick.	Refer to EN 60079-14

At an ambient temperature between -40 and +70°C

Note: The specified operating temperature of the BA358E is -20 to +70°C. At temperatures below -20°C the instrument will continue to totalise but the display will not function.

A1.3 Maintenance

ENSURE PLANT SAFETY BEFORE STARTING MAINTENANCE

Live maintenance is permitted on intrinsically safe equipment installed in a hazardous area, but only certified test equipment should be used.

All models have IP66 front of panel protection and a gasket is provided to seal the joint between the instrument and the mounting panel thus preventing dust ingress from the outside of the mounting panel. The rear of the instruments is not sealed, but ATEX dust certification is dependent on the internal conformal coating of the instrument, so dust ingress is acceptable except for use in IIIC conductive dusts – see A1.4. However, it is good practice to minimise the amount of dust accumulating on the rear of the instrument.

A1.4 Special conditions for use in IIC dusts

The BA358E Rate Totaliser ATEX certificate has an 'X' suffix indicating that special conditions for safe use are required for installation in IIC dust atmospheres, the certificate states:

'For use in Group IIC conductive gas atmospheres, the instrument shall be mounted such that the instrument terminals have at least IP6X protection.'

To prevent the Rate Totaliser terminals becoming contaminated by conductive dust:

The BA358E should be installed in a panel, cubicle or enclosure providing a minimum of IP6X protection.

The gasket supplied to seal the joint between the BA358E Rate Totaliser and the mounting panel must be installed, and the instrument secured with four panel mounting clamps.

Note: These special installation conditions only apply to BA358E Rate Totalisers exposed to IIC conductive dust atmospheres.

Appendix 2 IECEX certification

A2.0 The IECEX Certification Scheme

IECEX is a global certification scheme for explosion protected products which aims to harmonise international certification standards. For additional information about the IECEX certification scheme and to view the BEKA associate certificates, please visit www.iecex.com

A2.1 IECEX Certificate of Conformity

The BA358E loop powered Rate Totaliser and the optional accessories have been issued with an IECEX Certificate of Conformity number IECEX ITS 11.0015X which specifies the following certification codes:

Ex ia IIC T5 Ga
Ex ia IIIC T80°C Da
Ta = -40°C to 70°C

The specified gas and dust intrinsic safety parameters are identical to the ATEX safety parameters described in this manual.

The IECEX certificate may be downloaded from www.beka.co.uk, www.iecex.com or requested from the BEKA sales office.

A2.2 Installation

The IECEX and ATEX certificates specify identical safety parameters and installation requirements for both approvals as defined by IEC / EN 60079-14. The ATEX installation requirements specified in the main section and Appendix 1 of this manual may therefore be used for IECEX installations, but the local code of practice should also be consulted.

A2.3 Special conditions for use in IIIC dusts

The IECEX certificate for the loop powered BA358E Rate Totaliser has an 'X' suffix indicating that special conditions for safe use are required for installation in IIIC dust atmospheres, the certificate states:

'For use in Group IIIC conductive gas atmospheres, the instrument shall be mounted such that the instrument terminals have at least IP6X protection.'

To prevent the field terminals becoming contaminated by conductive dust:

The Rate Totaliser must be installed in a panel, cubicle or enclosure providing a minimum of IP6X protection.

The gasket supplied to seal the joint between the Rate Totaliser and the mounting panel must be used, and the instrument must be secured with four panel mounting clamps.

Note: These special installation conditions only apply to BA358E Rate Totalisers exposed to IIIC conductive dust atmospheres.

Appendix 3
FM Approval for use in the USA and
cFM Approval for use in Canada

A3.0 Factory Mutual Approval

For installations in the USA and Canada the BA358E has FM and cFM intrinsic safety and nonincendive approval, project identifications 3041487 and 3041487C. Copies of the Certificates of Compliance are available from the BEKA associates sales office and www.beka.co.uk

A3.1 Intrinsic safety approval

The BA358E Rate Totaliser is approved to FM Class 3610 intrinsic safety standard for use in Division 1 and 2 hazardous (classified) locations. Installations must comply with BEKA associates Control Drawing CI300-72, which is attached to this Appendix, ANSI/ISA RP12.06.01 'Installation of Intrinsically Safe Systems for Hazardous (Classified) Locations' and with the National Electrical Code ANSI/NFPA70. Installations in Canada must comply with the Canadian Electrical Code C22.2

The BA358E has a T5 rating at ambient temperatures up to +70°C and may be used with the following gases:

Intrinsic Safety	
Division 1 or 2	
Class I	Group A & B Group C Group D
Zone 0, 1 or 2	
Class 1	Group IIC Group IIB Group IIA

The FM and cFM entity parameters are similar to the ATEX and IECEx parameters and the systems shown in section 4 of this manual may therefore also be used for FM and cFM installations.



A3.2 Nonincendive approval

The BA358E Rate Totaliser is also approved to nonincendive standard FM Class 3611 allowing installation in Division 2 hazardous (classified) locations without the need for Zener barriers or galvanic isolators. US installations must comply with the BEKA associates Control Drawing CI300-73, which is attached to this Appendix, and with the National Electrical Code ANSI/NFPA70.

Canadian nonincendive installations must comply with the Canadian Electrical Code C22.2 and with BEKA associates Control Drawing CI300-73, which is attached to this Appendix.

The BA358E has a T5 rating at ambient temperatures up to +70°C and may be used with the following gases and dusts:

Nonincendive	
Division 2	
Class I	Group A & B Group C Group D
Class II	Groups E, F & G
Class III	
Zone 2	
Class I	Group IIC Group IIB Group IIA

Iss.		Date		Modification		Ckd.		Appd.			
1		13.10.2010		New drawing							
2		27.06.2012		ATEX parameters added. No change to this sheet							
 <p>BEKA associates Hitchin England company confidential, copyright reserved.</p>											
<p>Notes</p> <ol style="list-style-type: none"> The associated protective barriers and galvanic isolators shall be FM approved and the manufacturers instructions shall be followed when installing this equipment. For installations in Canada the associated protective barriers and galvanic isolators shall be cFM or CSA approved and the manufacturers installation drawings shall be followed when installing this equipment. The unclassified location equipment shall not use or generate more than 250V rms or 250V dc. Installations shall be in accordance with ANSI/ISA RP 12.06.01 'Installation of Intrinsically Safe Systems for Hazardous (Classified) Locations' and the National Electrical Code ANSI/NFPA 70. Installations in Canada shall be in accordance with the Canadian Electrical Code C22.2. One single channel or one two channel associated protective barrier or galvanic isolator with entity parameters complying with the following requirements: <ul style="list-style-type: none"> Uo equal or less than The lowest Ui of the FM, cFM or CSA approved apparatus installed in the loop. Io equal or less than The lowest Ii of the FM, cFM or CSA approved apparatus installed in the loop. Po equal or less than The lowest Pi of the FM, cFM or CSA approved apparatus installed in the loop. Lo equal or greater than The sum of the cable inductances and the internal inductances Li of each FM, cFM or CSA approved apparatus in the loop. Co equal or greater than The sum of the cable capacitance and the internal capacitance Ci of each FM, cFM or CSA approved apparatus in the loop. 											
Iss.		Date		Title		Drawn		Checked		Scale	
1		13.10.2010		FM & cFM Intrinsically Safe Control Drawing for BA304E, BA307E & 308E 4 DIGIT INDICATORS BA324E, 327E & BA328E 5 DIGIT INDICATORS BA354E & BA358E RATE TOTALISERS		RC				-	
2		27.06.2012				Drawing No.		Sheet 3		CI300-72	

Iss.	Date	Modification	Ckd.	Appd.	<p>BEKA associates Hitchin England company confidential, copyright reserved.</p>	<p>11. Safety parameters</p> <p>4/20mA input terminals 1, 2, 3 & 4</p> <p> $U_i = 30V$ $I_i = 200mA$ $P_i = 0.84W$ $U_o = 1.1V$ $I_o = 3mA$ $P_o = 4.5mW$ </p> <p> $C_i = 13nF$ $L_i = 0.01mH$ </p> <p>Separately powered backlight terminals 12 & 14.</p> <p> $U_i = 30V$ $I_i = 200mA$ $P_i = 0.84W$ </p> <p> $C_i = 13nF$ $L_i = 0.01mH$ </p> <p>Reset terminals RS1 & RS2 BA354E & BA358E rate totaliser only.</p> <p> $U_i = 30V$ $I_i = 200mA$ $P_i = 0.84W$ $U_o = 6V$ $I_o = 2.5mA$ $P_o = 3.8mW$ </p> <p> $C_i = 13nF$ $L_i = 0.01mH$ $C_o = 53nF$ $L_o = 0.79mH$ </p>		
							3	03.10 2012
Iss.	Date	Modification	Ckd.	Appd.	<p>12. BA304E, BA307E, BA308E, BA324E, BA327E & BA328E loop powered Indicators and BA354E & BA358E loop powered Rate Totalisers.</p>	<p>4/20mA input terminals 1, 2, 3, 4, 12 & 13 & loop powered backlight.</p> <p> $U_i = 30V$ $I_i = 200mA$ $P_i = 0.84W$ $U_o = 1.1V$ $I_o = 3mA$ $P_o = 4.5mW$ </p> <p> $C_i = 13nF$ $L_i = 0.01mH$ </p> <p>Alarm terminals 8, 9, 10 and 11</p> <p> $U_i = 30V$ $I_i = 200mA$ $P_i = 0.84W$ $U_o = 1.47V$ $I_o = 1.0\mu A$ $P_o = 2.2\mu W$ </p> <p> $C_i = 24nF$ $L_i = 0.01mH$ </p>		
1	15.10 2010	New drawing			<p>Title FM & cFM Nonincendive Control Drawing for BA304E, BA307E & 308E 4 DIGIT INDICATORS BA324E, 327E & BA328E 5 DIGIT INDICATORS BA354E & BA358E RATE TOTALISERS</p>	Drawn RC	Checked 	Scale -
	11.04 2012	ATEX parameters added.				<p>Drawing No. CI300-73</p> <p>Sheet 5</p>		