

1/16 - 1/8 - 1/4 DIN VMD CONTROLLERS CONCISE PRODUCT MANUAL (59377-3)

CAUTION: Installation should be only performed by technically competent personnel. Local Regulations regarding electrical installation & safety must be observed.

1. INSTALLATION

The models covered by this manual have three different DIN case sizes (refer to section 10). Some installation details vary between models. These differences have been clearly shown.

Note: The functions described in sections 2 thru 9 are common to all models.

Installing Option Modules

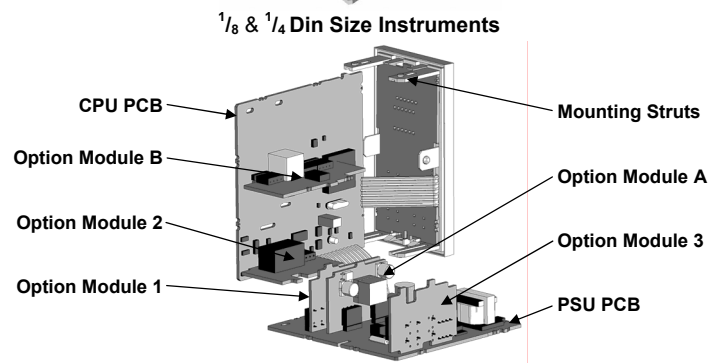
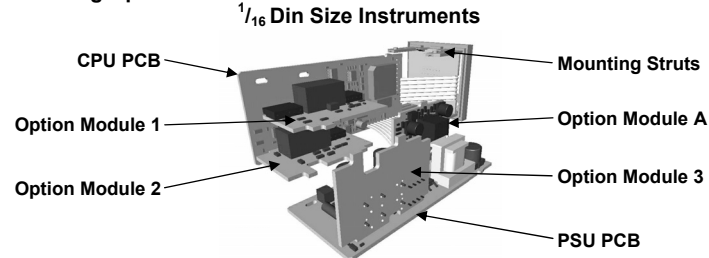

- To access modules 1, A or B, first detach the PSU and CPU boards from the front by lifting first the upper, and then lower mounting struts. Gently separate the boards.
- Plug the required option modules into the correct connectors, as shown below.
 - Locate the module tongues in the corresponding slot on the opposite board.
 - Hold the main boards together while relocating back on the mounting struts.
 - Replace the instrument by aligning the CPU and PSU boards with their guides in the housing, then slowly push the instrument back into position.

Note: Option modules are automatically detected at power up.

Option Module Connectors

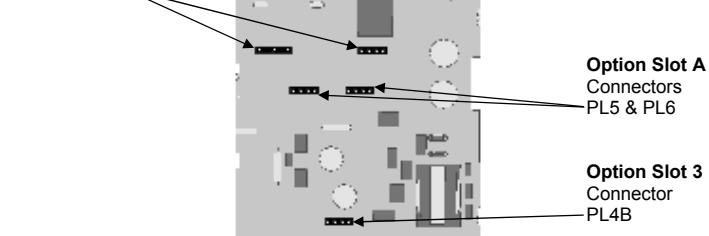
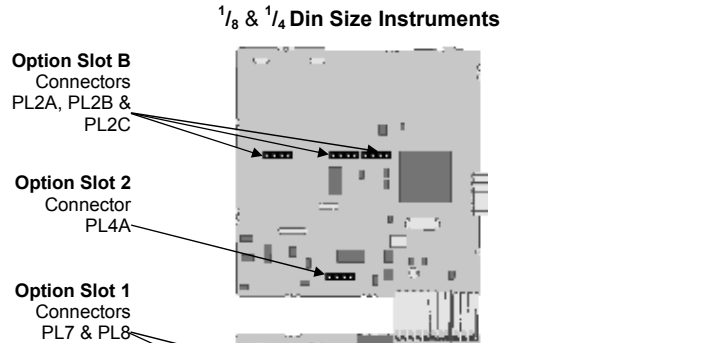
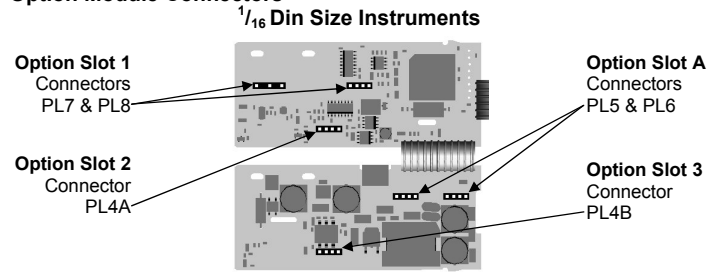

Panel-Mounting

The mounting panel must be rigid, and may be up to 6.0mm (0.25inch) thick. Cut-out sizes are:

Cut-Out Dim A
1/16 & 1/8 Din = 45mm
1/4 Din = 92mm

Cut-Out Dim B
1/16 Din = 45mm
1/8 & 1/4 Din = 92mm

For *n* multiple instruments mounted side-by-side, cut-out A is 48*n*-4mm (1/16 & 1/8 Din) or 96*n*-4mm (1/4 Din)

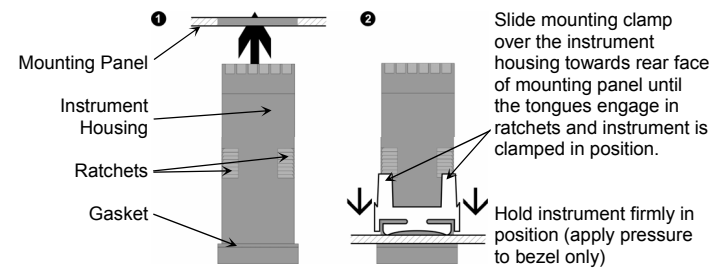

CAUTION: Do not remove the panel gasket; it is a seal against dust and moisture.

Rear Terminal Wiring

USE COPPER CONDUCTORS (EXCEPT FOR T/C INPUT)
Single Strand wire gauge: Max 1.2mm (18SWG)

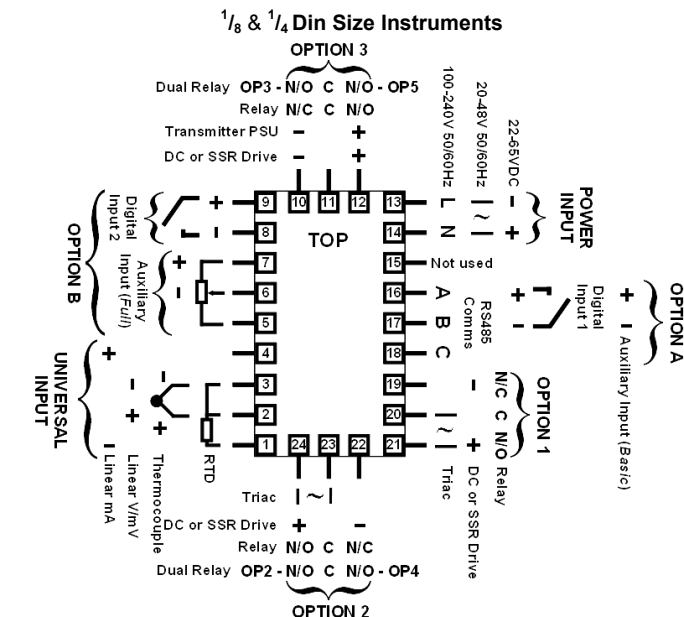
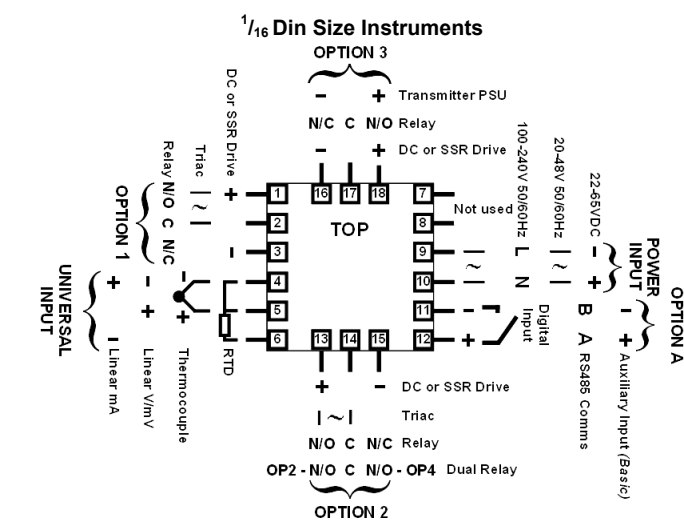

Note: These diagrams show all possible option combinations. The actual connections required depend on the exact model and options fitted.

Note: This controller uses Three-Point Stepping Control. This requires two identical outputs (2 Relays, 2 Triacs, 2 SSR Drivers or 1 Dual Relay) for the valve Open & Close functions. See Output Usage 1-5 in Configuration Mode.

CAUTION: Check information label on housing for correct operating voltage before connecting supply to Power Input
Fuse: 100 - 240V ac - 1amp anti-surge
24/48V ac/dc - 315mA anti-surge

Note: At first power-up the message `Go to Conf` is displayed, as described in section 7 of this manual. Access to other menus is denied until Configuration Mode is completed.

2. SELECT MODE

Select mode is used to access the configuration and operation menu functions. It can be accessed at any time by holding down **⏏** and pressing **⏏**. In select mode, press **⏏** or **⏏** to choose the required mode, press **⏏** to enter. An unlock code is required to prevent unauthorised entry to Configuration, & Setup modes. Press **⏏** or **⏏** to enter the unlock code, then press **⏏** to proceed.

Mode	Upper Display	Lower Display	Description	Default Unlock Codes
Operator	OPtr	SLCt	Normal operation	None
Set Up	SEtP	SLCt	Tailor settings to the application	10
Configuration	ConF	SLCt	Configure the instrument for use	20
Product Info	inFo	SLCt	Check manufacturing information	None
Auto-Tuning	Autun	SLCt	Invoke Pre-Tune or Self-Tune	0

Note: The instrument will always return automatically to Operator mode if there is no key activity for 2 minutes.

3. CONFIGURATION MODE

First select Configuration mode from Select mode (refer to section 2). Press **⏏** to scroll through the parameters, then press **⏏** or **⏏** to set the required value. Press **⏏** to accept the change, otherwise parameter will revert to previous value. To exit from Configuration mode, hold down **⏏** and press **⏏**, to return to Select mode.

Note: Parameters displayed depends on how instrument has been configured. Refer to user guide (available from your supplier) for further details. Parameters marked ** are repeated in Setup Mode.

Parameter	Lower Display	Upper Display	Adjustment range & Description	Default Value	
Input Range/Type	inPt		See following table for possible codes	JC	
Code	Input Type & Range	Code	Input Type & Range	Code	Input Type & Range
bC	B: 100 - 1824 °C	LC	L: 0.0 - 537.7 °C	P24F	PtRh20% vs 40%: 32 - 3362 °F
bF	B: 211 - 3315 °F	LF	L: 32.0 - 999.9 °F	PtC	Pt100: -199 - 800 °C
cC	C: 0 - 2320 °C	nC	N: 0 - 1399 °C	PtF	Pt100: -328 - 1472 °F
cF	C: 32 - 4208 °F	nF	N: 32 - 2551 °F	PtL	Pt100: -128.8 - 537.7 °C
JC	J: -200 - 1200 °C	rC	R: 0 - 1759 °C	PtH	Pt100: -199.9 - 999.9 °F
JF	J: -328 - 2192 °F	rF	R: 32 - 3198 °F	S	S: 0 - 1762 °C
JL	J: -128.8 - 537.7 °C	SC	S: 0 - 1762 °C	0.20	0 - 20 mA DC
JF	J: -199.9 - 999.9 °F	SF	S: 32 - 3204 °F	4.20	4 - 20 mA DC
HC	K: -240 - 1373 °C	tC	T: -240 - 400 °C	0.50	0 - 50 mV DC
HF	K: -400 - 2503 °F	tF	T: -400 - 752 °F	10.50	10 - 50 mV DC
HL	K: -128.8 - 537.7 °C	tL	T: -128.8 - 400.0 °C	0.5	0 - 5 V DC
HF	K: -199.9 - 999.9 °F	tF	T: -199.9 - 752.0 °F	1.5	1 - 5 V DC
LC	L: 0 - 762 °C	P24C	PtRh20% vs. 40%: 0 - 1850 °C	0.10	0 - 10 V DC
LF	L: 32 - 1403 °F	P24F	PtRh20% vs. 40%: 0 - 1850 °C	2.10	2 - 10 V DC

Note: Decimal point shown in table indicates temperature resolution of 0.1°

Parameter	Lower Display	Upper Display	Adjustment range & Description	Default Value
Scale Range Upper Limit	rUL		Scale Range Lower Limit +100 to Range Maximum	Range max (Lin=1000)
Scale Range Lower Limit	rLL		Range Minimum to Scale Range Upper Limit -100	Range min (Linear=0)
Decimal point position	dPoS		0=xxxx, 1=xxx.x, 2=xx.xx, 3=x.xxx (non-temperature ranges only)	1
Primary Output Control Action	rEu		Reverse Acting	rEu
	dIr		Direct Acting	
Motor Travel Time	tr		0.05 to 5.00 (5 secs to 5 mins 0 secs) Time Valve takes to move between its physical end stops (full Open to full Closed).	1.00
Alarm 1Type	ALA1		P_H Process High Alarm P_Lo Process Low Alarm bRNd Band Alarm nonE No alarm	P_H
High Alarm 1 value**	PhA1		Range Minimum to Range Maximum in display units	Range Max
Low Alarm 1 value**	PLA1		Range Minimum to Range Maximum in display units	Range Min
Band Alarm 1 value**	bAL1		1 LSD to span from setpoint in display units	5
Dev. Alarm 1 value**	dAL1		+/- Span from setpoint in display units	5
Alarm 1 Hysteresis**	AHY1		1 LSD to full span in display units	1
Alarm 2 Type**	ALA2		Options as for alarm 1	P_Lo
High Alarm 2 value**	PhA2		Options as for alarm 1	Range Max
Low Alarm 2 value**	PLA2		Options as for alarm 1	Range Min
Band Alarm 2 value**	bAL2		Options as for alarm 1	5

Parameter	Lower Display	Upper Display	Adjustment range & Description	Default Value
Dev. Alarm 2 Value**	dAL2		Options as for alarm 1	5
Alarm 2 Hysteresis**	AHY2		Options as for alarm 1	1
Loop Alarm	LAEn		d SA (disabled) or EnAb (enabled)	d SA
Alarm Inhibit	Inh		nonE No alarms Inhibited ALA1 Alarm 1 inhibited ALA2 Alarm 2 inhibited bAbh Alarm 1 and alarm 2 inhibited	nonE
Output 1 Usage*	USE1		OPN Valve Open CLS Valve Close A1_d Alarm 1, Direct A1_r Alarm 1, Reverse A2_d Alarm 2, Direct A2_r Alarm 2, Reverse LP_d Loop Alarm, Direct LP_r Loop Alarm, Reverse Or_d Logical Alarm 1 OR 2, Direct Or_r Logical Alarm 1 OR 2, Reverse Ad_d Logical Alarm 1 AND 2, Direct Ad_r Logical Alarm 1 AND 2, Reverse rEtS Retransmit SP Output rELP Retransmit PV Output	OPN
Linear Output 1 Range	tYP1		0.5 0 to 5 V DC output 0.10 0 to 10 V DC output 2.10 2 to 10 V DC output 0.20 0 to 20 mA DC output 4.20 4 to 20 mA DC output	0.10
Retransmit Output 1 Scale maximum	roIH		-1999 to 9999 (display value at which output will be maximum)	Range max
Retransmit Output 1 Scale minimum	roIL		-1999 to 9999 (display value at which output will be minimum)	Range min
Output 2 Usage*	USE2		As for output 1	Sec or AI2
Linear Output 2 Range	tYP2		As for output 1	0.10
Retransmit Output 2 Scale maximum	ro2H		-1999 to 9999 (display value at which output will be maximum)	Range max
Retransmit Output 2 Scale minimum	ro2L		-1999 to 9999 (display value at which output will be minimum)	Range min
Output 3 Usage*	USE3		As for output 1	A1_d
Linear Output 3 Range	tYP3		As for output 1	0.10
Retransmit Output 3 Scale maximum	ro3H		-1999 to 9999 (display value at which output will be maximum)	Range max
Retransmit Output 3 Scale minimum	ro3L		-1999 to 9999 (display value at which output will be minimum)	Range min
Output 4 Usage*	USE4		As for output 1 except Retransmit of PV or SP is not possible.	OPN
Output 5 Usage*	USE5		As for output 1 except Retransmit of PV or SP is not possible.	A1_d
Display Strategy	d SP		1, 2, 3, 4, 5, 6 or 7 (refer to section 8)	1
Serial Communications Protocol	Prot		r7bn Modbus with no parity r7bE Modbus with Even Parity r7bo Modbus with Odd Parity	r7bn
Serial Communications Bit Rate	bAud		1.2 1.2 kbps 2.4 2.4 kbps 4.8 4.8 kbps 9.6 9.6 kbps 19.2 19.2 kbps	4.8
Comms Address	Addr		1 to 255	1
Comms Write	CoEn		r_LW Read/Write r_D Read only	r_LW
Auxiliary Input A Usage	A PA		rSP Remote Setpoint (basic) P_in Valve Position Indication (basic)	P_in
Auxiliary Input B Usage	A PB		rSP Remote Setpoint (Full) P_in Valve Position Indication (Full)	P_in
Digital Input 1 Usage	d I1		d S1 Setpoint 1 / Setpoint 2 select** d AS Automatic / Manual select	d S1
Digital Input 2 Usage	d I2		d S1 Setpoint 1 / Setpoint 2 select** d rS Automatic / Manual select d rS Remote / Local setpoint select	d rS

Note: d I2 has priority over d I1 if both are configured for the same usage. If d I1 or d I2 = d S1 the remote setpoint (RSP) input is disabled.

Continued on next page...

Parameter	Lower Display	Upper Display	Adjustment range & Description	Default Value
Remote Auxiliary Input Range	r _{inp}	0_20	0 to 20 mA DC input	0_10
		4_20	4 to 20 mA DC input	
		0_10	0 to 10 V DC input	
		2_10	2 to 10 V DC input	
		0_5	0 to 5 V DC input	
		1_5	1 to 5 V DC input	
		100	0 to 100mV DC input	
		Potentiometer (2KΩ minimum)		
RSP Upper Limit	rSPu	-1999 to 9999. Remote SP for max. input	Range max	
RSP Lower Limit	rSPL	-1999 to 9999. Remote SP for min. input	Range min	
RSP Offset	rSPo	Constrained within Scale Range Upper & Scale Range Lower limits		0
Configuration Lock Code	CLoc	0 to 9999. Unlock Code for this mode		20

4. SETUP MODE

Note: Configuration must be completed before adjusting Setup parameters. First select Setup mode from Select mode (refer to section 2). The MAN LED will light while in Setup mode. Press to scroll through the parameters, then press or to set the required value. To exit from Setup mode, hold down and press to return to Select mode. **Note: Parameters displayed depends on how instrument has been configured.**

Parameter	Lower Display	Upper Display Adjustment Range & Description	Default Value
Input Filter Time Constant	F _{ILT}	0.0 (Off) or 0.5 to 100.0 secs.	2.0
Process Variable Offset	OFFS	±Span of controller	0
Primary Proportional Band	P _{bP}	0.5 to 999.9 % of input span	10.0
Automatic Reset (Integral Time)	ArSt	0.01 to 99.99 1 sec to 99 mins 59 secs	5.00
Rate (Derivative Time)	rAtE	0.00 to 99.99 0 sec to 99 mins 59 secs	0.00
Setpoint Upper Limit	SPuL	Current Setpoint to Range max	R/max
Setpoint Lower limit	SPLL	Range min to Current Setpoint	R/min
Minimum Motor On Time	tOn	0.0 secs to (Motor Travel Time / 10) secs. The minimum drive effort to begin moving valve.	0.0
Set Valve Open Position	P _{cuL}	See instructions below to set the valve's fully open and closed positions.	Max. Aux.
Set Valve Closed Position	P _{clL}		Min. Aux.
Valve Open Limit	P _{uL}	P _{uL} + 1 to 100. The maximum position valve will be driven to	100
Valve Closed Limit	P _{lL}	0 to P _{uL} - 1. The minimum position valve will be driven to	0
High Alarm 1 value	PhA1	Range Minimum to Range Maximum	R/max
Low Alarm 1 value	PLA1		R/min
Deviation Alarm 1 Value	dAL1	±Span from SP in display units	5
Band Alarm 1 value	bAL1	1 LSD to span from setpoint	5
Alarm 1 Hysteresis	AHY1	1 LSD to full span in display units	1
High Alarm 2 value	PhA2	Range Minimum to Range Maximum	R/max
Low Alarm 2 value	PLA2		R/min
Deviation Alarm 2 Value	dAL2	±Span from SP in display units	5
Band Alarm 2 value	bAL2	1 LSD to span from setpoint	5
Alarm 2 Hysteresis	AHY2	1 LSD to full span in display units	1
Auto Pre-tune	APt		
Auto/manual Control selection	PoEn		
Setpoint Select shown in Operator Mode	SSEn		
Setpoint ramp adjustment shown in Operator Mode	SPr		
SP Ramp Rate Value	rP	1 to 9999 units/hour or Off (blank)	Off
Setpoint Value	SP	Scale range upper to lower limits. (when dual or remote setpoint options are used, SP is replaced by SP1 & SP2 or LSP - or - before the legend indicates the currently active SP)	Scale Range Minimum
Local Setpoint Value	LSP		
Setpoint 1 Value	SP1		
Setpoint 2 Value	SP2		
Setup Lock Code	SLoc	0 to 9999	10

Setting the Valve Opened & Valve Closed Positions

With P_{cuL} in the lower display press . The top display shows oPnU. Press to drive open the valve until it reaches the "fully open" end stop. Press . The top display will go Blank and the Auxiliary Input value will be measured and stored as the value equal to the fully open valve position. Press . The lower display shows P_{clL}. Press . The top display shows cLSG. Press to drive closed the valve until it reaches the "fully closed" end stop. Press . The top display will go Blank and the Auxiliary Input value will be measured and stored as the value equal to the fully closed valve position.

5. AUTOMATIC TUNING MODE

First select Automatic tuning mode from Select mode (refer to section 2). Press to scroll through the modes, then press or to set the required value. To exit from Automatic tuning mode, hold down and press , to return to Select mode. Pre-tune is a single-shot routine and is thus self-disengaging when complete. If APt in Setup mode = EnAb, Pre-tune will attempt to run at every power up*. Refer to the full user guide (available from your supplier) for details on controller tuning.

Parameter	Lower Display	Upper Display	Default Value
Pre-Tune	Ptun	On or OFF. *Pre-tune will not engage if setpoint is ramping, or the PV is less than 5% of input span from the setpoint. Indication remains OFF	OFF
Self-Tune	Stun		
Tune Lock	tLoc	0 to 9999	0

6. PRODUCT INFORMATION MODE

First select Product information mode from Select mode (refer to section 2). Press to view each parameter. To exit from Product Information mode, hold down and press to return to Select mode. **Note: These parameters are all read only.**

Parameter	Lower Display	Upper Display	Description
Input type	In_1	Un_1	Universal input
Option 1 module type fitted	OPn1	nonE	No option fitted
		rLY	Relay output
		SSr	SSR drive output
		tr_1	Triac output
Option 2 module type fitted	OPn2	L in	Linear DC voltage / current output
		nonE	No option fitted
		drLY	Dual Relay output
		rLY	Relay output
Option 3 module type fitted	OPn3	SSr	SSR drive output
		tr_1	Triac output
		L in	Linear DC voltage / current output
		dc24	Transmitter power supply
Auxiliary Option A module type fitted	OPnA	nonE	No option fitted
		r4B5	RS485 communications
		dIG1	Digital Input*
		rSP1	Auxiliary Input (basic)*
Auxiliary Option B module type fitted	OPnB	nonE	No option fitted
		rSP1	Auxiliary Input (full) and Digital Input 2*
Firmware type	FLW		Value displayed is firmware type number
Firmware issue	ISS		Value displayed is firmware issue number
Product Revision Level	PRL		Value displayed is Product Revision level
Date of manufacture	d0M		Manufacturing date code (mmyy)
Serial number 1	S _{n1}		First four digits of serial number
Serial number 2	S _{n2}		Middle four digits of serial number
Serial number 3	S _{n3}		Last four digits of serial number

7. MESSAGES & ERROR INDICATIONS

These messages indicate that an error has occurred, or there is a problem with the process variable input connection or signal.

Caution: Do not continue with the process until the issue is resolved.

Parameter	Upper Display	Lower Display	Description
Instrument parameters are in default conditions	GoTo	Conf	Configuration & Setup required. This screen is seen at first turn on, or if hardware configuration has been changed. Press to enter the Configuration Mode, next press or to enter the unlock code number, then press to proceed
Input Over Range	CHH	Normal	Process variable input > 5% over-range
Input Under Range	CLL	Normal	Process variable input > 5% under-range
Input Sensor Break	OPEN	Normal	Break detected in process variable input sensor or wiring.
Aux. Over Range	Normal	CHH**	Auxiliary input over-range
Aux. Under Range	Normal	CLL**	Auxiliary input under-range
Auxiliary Input Break	Normal	OPEN**	Break detected in Auxiliary input signal
Option 1 Error		OPn1	Option 1 module fault
Option 2 Error		OPn2	Option 2 module fault
Option 3 Error		OPn3	Option 3 module fault
Option A Error		OPnA	Option A fault or Aux fitted in both A & B
Option B Error		OPnB	Option B module fault

8. OPERATOR MODE

This mode is entered at power on, or accessed from Select mode (see section 2). **Note: All Configuration mode and Setup mode parameters must be set as required before starting normal operations.** Press to scroll through the parameters, then press or to set the required value. **Note: All Operator Mode parameters in Display strategy 6 are read only (see d_{IS} in configuration mode), they can only be adjusted via Setup mode.**

Upper Display	Lower Display	Display Strategy and When Visible	Description
PV Value	Active SP Value	1 & 2 (initial screen)	PV and target value of selected SP. Local Setpoints are adjustable in Strategy 2
PV Value	Actual SP Value	3 & 6 (initial screen)	PV and actual value of selected SP (e.g. ramping SP value). Read only
PV Value	(Blank)	4 (initial screen)	Process variable only. Read only
Active SP Value	(Blank)	5 (initial screen)	Target value of selected setpoint only. Read only
PV Value	Auxiliary Input Value	7 (initial screen)	PV and Valve Position or Flow. Read only
SP Value	SP	1 & 3 - 7 if digital input is not d _{IS} 1 and RSP not configured	Target value of SP. Adjustable except in Strategy 6
SP1 Value	SP1	Digital input = d _{IS} 1. - lit if active SP = SP1	Target value of SP1. Adjustable except in Strategy 6
SP2 Value	SP2	Digital input = d _{IS} 1. - lit if active SP = SP2	Target value of SP2. Adjustable except in Strategy 6
Local SP Value	LSP	RSP fitted. - or - lit if the active SP = LSP	Target value of local setpoint. Adjustable except in Strategy 6
Remote SP Value	rSP	RSP fitted. - or - lit if the active SP = rSP	Target value of remote setpoint. Read only
d _{IG} 1, LSP or rSP	SPS	RSP is fitted, digital input is not d _{IS} 1 and SSEn is enabled in Setup mode	Selects local/remote active setpoint. LSP = local SP, rSP = remote SP. d _{IG} 1 = selection via digital input (if configured). Note: selecting LSP or rSP will override digital input, active SP indication changes to - Adjustable except in Strategy 6
Actual SP Value	SPrP	rP is not blank	Actual (ramping) value of selected SP. Read only
Ramp Rate	rP	SPr enabled in Setup mode	SP ramping rate, in units per hour. Adjustable except in Strategy 6
Active Alarm Status	ALSt	When one or more alarms are active. ALM indicator will also flash	Alarm 2 active Alarm 1 active Loop Alarm active

Manual Valve Control

If PoEn is set to EnAb in Setup mode, manual control can be selected/de-selected by pressing the key in Operator mode, via serial communications, or by changing the status of a digital input if d_{IG}1 or d_{IG}2 has been configured for d_{AS} in Configuration mode. While in Manual Control mode, the indicator will flash and the lower display will show P_{VAL}. If Valve Position Indication is configured, the lower display will show P_{xxx} instead of P_{VAL}, where xxx is the valve position as read by the Auxiliary Input. PO means the valve is fully closed, P₁₀₀ means the valve is fully opened.

Press to move the valve mother in the "open" direction or to move the valve mother in the "close" direction. Keep pressing the key until the desired valve position is achieved

9. SERIAL COMMUNICATIONS

Refer to the full user guide (available from your supplier) for details.

10. SPECIFICATIONS

UNIVERSAL INPUT

Thermocouple: ±0.1% of full range, ±1LSD (±1°C for Thermocouple CJC).
Calibration: BS4937, NBS125 & IEC584.
PT100 Calibration: ±0.1% of full range, ±1LSD.
BS1904 & DIN43760 (0.00385Ω/Ω°C).
DC Calibration: ±0.1% of full range, ±1LSD.
Sampling Rate: 4 per second.
Impedance: >10MΩ resistive, except DC mA (5Ω) and V (47kΩ).
Sensor Break Detection: Thermocouple, RTD, 4 to 20 mA, 2 to 10V and 1 to 5V ranges only. "Close Valve" outputs turn ON.
Isolation: Isolated from all outputs (except SSR driver).
Universal input must not be connected to operator accessible circuits if relay outputs are connected to a hazardous voltage source. Supplementary insulation or input grounding would then be required.

AUXILIARY INPUT

Calibration: ±0.25% of input range ±1 LSD.
Sampling Rate: 4 per second.
Sensor Break Detection: 4 to 20 mA, 2 to 10V and 1 to 5V ranges only. Valve control outputs turn off if RSP is the active SP.
Isolation: Slot A - Basic isolation, Slot B - Reinforced safety isolation from other inputs and outputs.

DIGITAL INPUTS

Volt-free(or TTL): Open(2 to 24VDC) = SP1, Local SP or Auto Mode, Closed(<0.8VDC) = SP2, Remote SP or Manual Mode.
Isolation: Reinforced safety isolation from inputs and other outputs.

OUTPUTS

Relay

Contact Type & Rating: Single pole double throw (SPDT); 2A resistive. 120VAC max. (240V for alarm or indirect switching of valves).
Lifetime: >500,000 operations at rated voltage/current.
Isolation: Basic Isolation from universal input and SSR outputs.

Dual Relay

Contact Type & Rating: 2 x single pole single throw, with shared common; 2A resistive. 120VAC max. (240V for alarm or indirect switching of valves).
Lifetime: >200,000 operations at rated voltage/current.
Isolation: Reinforced safety isolation from inputs and other outputs.

SSR Driver

Drive Capability: SSR drive voltage >10V into 500Ω min.
Isolation: Not isolated from universal input or other SSR driver outputs.

Triac

Operating Voltage: 20 to 140Vrms (280V max. for alarm or indirect switching of valves) @ 47 to 63Hz.

Current Rating: 0.01 to 1A (full cycle rms on-state @ 25°C); derates linearly above 40°C to 0.5A @ 80°C.

Isolation: Reinforced safety isolation from inputs and other outputs.

DC Linear

Resolution: 8 bits in 250mS (10 bits in 1s typical, >10 bits in >1s typical).
Isolation: Reinforced safety isolation from inputs and other outputs.

Transmitter PSU

Power Rating: 19 to 28V DC (24V nominal) into 910Ω minimum resistance.
Isolation: Reinforced safety isolation from inputs and other outputs.

SERIAL COMMUNICATIONS

Physical: RS485, at 1200, 2400, 4800, 9600 or 19200 bps.
Protocol: Modbus RTU.
Isolation: Reinforced safety isolation from all inputs and outputs.

OPERATING CONDITIONS (FOR INDOOR USE)

Ambient Temperature: 0°C to 55°C (Operating), -20°C to 80°C (Storage).
Relative Humidity: 20% to 95% non-condensing.
Supply Voltage and Power: 100 to 240VAC ±10%, 50/60Hz, 7.5VA (for mains powered versions), or 20 to 48VAC 50/60Hz 7.5VA or 22 to 65VDC 5W (for low voltage versions).

ENVIRONMENTAL

Standards: CE, UL, ULC.
EMI: Complies with EN61326 (Susceptibility & Emissions).
Safety: Complies with EN61010-1 & UL3121.
Considerations: Pollution Degree 2, Installation Category II.
Front Panel Sealing: To IP66 (IP20 behind the panel).

PHYSICAL

Front Bezel Size: 1/16 Din = 48 x 48mm, 1/8 Din = 96 x 48mm, 1/4 Din = 96 x 96mm.
Depth Behind Panel: 1/16 Din = 110mm, 1/8 & 1/4 Din = 100mm.
Weight: 0.21kg maximum.